

# Slim Fi - FiN

**Gas boilers with a cast-iron base,  
sealed chamber, automatic ignition  
and electronic flame modulation**

## User and Installer Manual



**BAXI S.p.A.**, one of the leading European companies in the production of heating and hot-water appliances for household use (wall-mounted gas boilers, free-standing boilers and electric water heaters) has obtained CSQ certification in accordance with UNI EN ISO 9001 standards.

This certification confirms that the Quality System of **BAXI S.p.A.** in Bassano del Grappa, where this boiler was manufactured, satisfies the strict UNI EN ISO 9001 standard covering all aspects of company organisation, manufacturing and distribution.

Dear Customer,

We are sure your new boiler will comply with all your requirements.

Purchasing one of the **BAXI** products satisfies your expectations: good functioning, simplicity and ease of use.

Read these instructions fully before installing or using the appliance: you can find useful information, which will help you to run your boiler correctly and efficiently.

*Do not leave any parts of the packaging (plastic bags, polystyrene, etc.) within children's reach as they are a potential source of danger.*

**BAXI** boilers bear the CE mark in compliance with the essential requirements as laid down in the following Directives:

- Gas Directive 90/396/CEE
- Performance Directive 92/42/CEE
- Electromagnetic Compatibility Directive 89/336/CEE
- Low voltage Directive 73/23/CEE



# CONTENTS

## Instructions pertaining to the user

1	General Information	pag.	4
2	Instruction prior to installation		4
3	Instruction prior to commissioning		4
4	Commissioning of the boiler		5
5	Room temperature adjustment		6
6	Turning off the boiler		6
7	Filling the boiler		6
8	Emptying the boiler		6
9	Prolonged standstill of the system		6
10	Safety devices indicators – meaning –		7
11	Gas conversion		7
12	Servicing instructions		7

## Instructions pertaining to the installer

1	Overall dimensions		8
2	General information		9
3	Instructions prior the installation		10
4	Installation		10
5	Electrical connection		16
6	Electrical diagram		17
7	Room thermostat connection		18
8	Connecting a programming timer		19
9	Domestic hot water storage tank connection		20
10	Connection of the external probe		24
11	Connection of the climatic regulator QAA73		25
12	Air vent and release of the pump		27
13	Regulation on the electronic card (PCB)		27
14	Gas conversion		28
15	Table of gas consumption and injectors		29
16	Regulation and safety devices		30
17	Check of combustion parameters		30
18	Specifications of flow rate/head at the plate		31
19	Hydraulic resistance performances		31
20	How to service and clean the boiler		31
21	Technical data		32

# Instructions pertaining to the user

The following instructions give important information for the commission and the use of the device.

The remarks and technical instructions, addressed to Service Engineers to help them to carry out a faultless installation, will be contained in the second part of this manual.

## 1. General description

The **SLIM** boilers are high-efficiency gas boilers with a cast-iron base, sealed combustion circuit, forced ventilation, direct burner ignition, electronic ionizing flame control and electronic modulation of the gas flow rate, to be used as generators in single-family hot-water heating systems.

The **SLIM** series is made in two versions.

**TABLE I**

**Ia: FiN models without plumbing accessories**

boiler models	nominal heating power kW	reduced heating power kW	num. exchanger elements
1.230 FiN	22,1	11,8	4
1.300 FiN	29,7	14,9	5

**Fi models with plumbing accessories**

boiler models	nominal heating power kW	reduced heating power kW	num. exchanger elements
1.230 Fi	22,1	11,8	4
1.300 Fi	29,7	14,9	5

## 2. Instructions prior to installation

This boiler is designed to heat water at a lower than boiling temperature at atmospheric pressure.

The boiler must be connected to a central heating system and to a DHW distribution system, in compliance with its performances and heat output.

Have the boiler installed by a Qualified Service Engineer and ensure the following operations are accomplished:

- Accurate purging of the whole pipe work in order to remove any deposits.
- Careful checking that the boiler is fit for operation with the type of gas available. For more details see the notice on the package and the label on the appliance itself.
- Careful checking that the flue terminal draft is appropriate, that the terminal is not obstructed and that no other appliance exhaust gases are expelled through the same flue duct, unless the flue is especially designed to collect the exhaust gas coming from more than one appliance, in conformity with the laws and regulations in force.

## 3. Instructions prior to commissioning

First commissioning of the boiler must be carried out by an authorized Service Engineer. Ensure the following operations are carried out:

- Compliance of boiler parameters with (electricity, water, gas) supply systems settings.
- Compliance of installation with the laws and regulations in force.
- Appropriate connection to the power supply and grounding of the appliance.

Electrical safety of the appliance is only guaranteed by correct grounding, in compliance with the applicable laws and regulations.

The boiler must be electrically connected to a 230 V single-phase + earth mains with the three-wire cable supplied, observing the polarity LIVE (L) - NEUTRAL (N).

Use a double-pole switch with a contact separation of at least 3mm in both poles.

In case you replace the power supply cable fit a HAR H05 VV-F 3x1 mm<sup>2</sup> cable with an 8 mm diameter max.

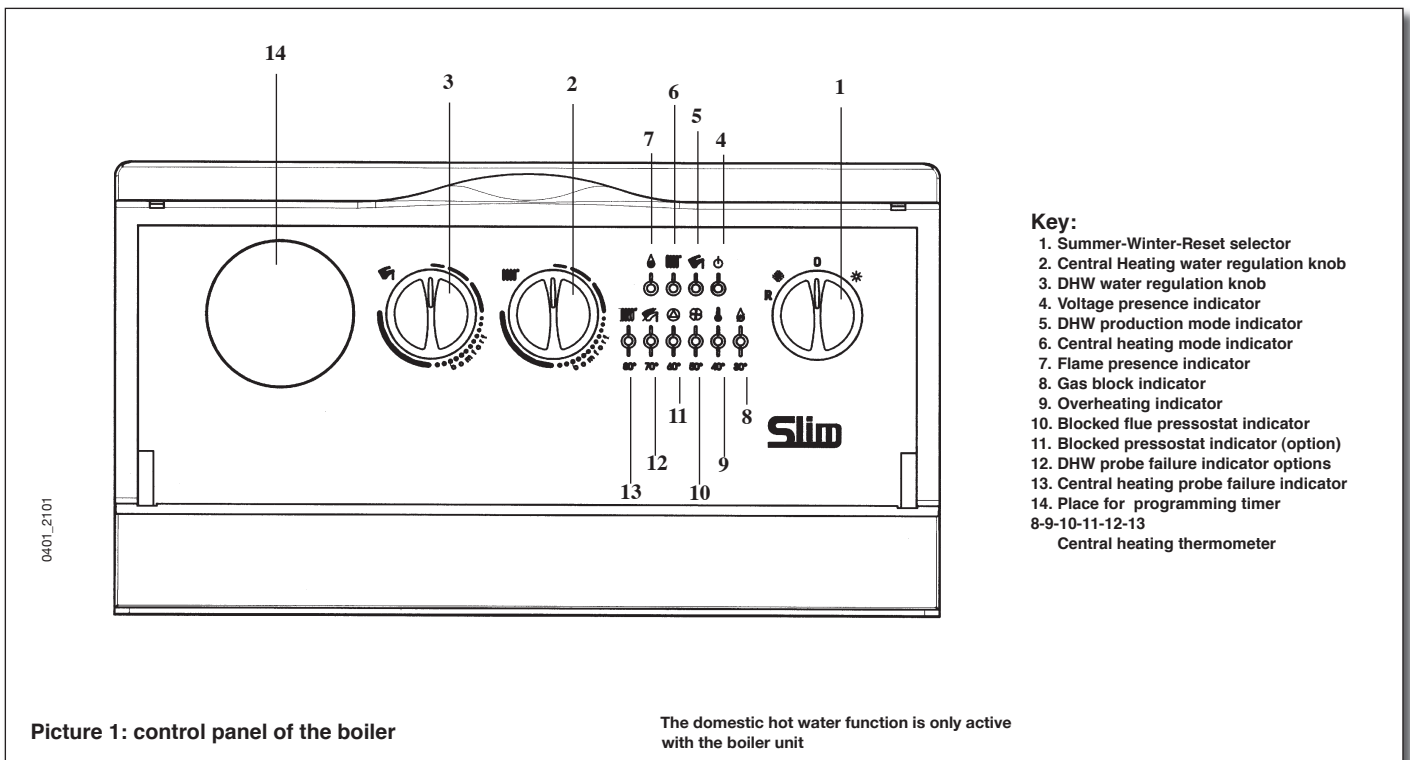

## 4. Commissioning of the boiler

To have access to the control system of the boiler, open the transparent panel which covers the control panel. The panel rotates down.

To open the upper door of the boiler pull on its upper corners so that the door will be released from the outer casing.

To correctly light the boiler proceed as follows:

- Provide power supply to the boiler;
- Open the gas cock;
- Verify that the system is full of water and the pressure is the right one (see point 7);
- Turn the selector switch (ref. 1 figure 1) to set the boiler on ❄️ winter operation.
- Regulate the room thermostat (if present) at the desired temperature.
- Set the Central Heating regulation knob (ref. 2 figure 1) in order to have the boiler at the desired temperature.

For a better energy saving we suggest you to set the regulation knobs in the “COMFORT” position, environment conditions permitting.

**Important:** when selector is set to ❄️ Winter (ref. 1 figure 1) you have to wait few minutes every time the heating regulation device switches off the burner (ref. 2 figure 2). If you want the burner to switch on immediately, turn the selector in position (O) and then switch it again, in winter position.

**Warning:** During first commissioning, until the air inside the gas pipes is not released, the burner may fail to light immediately and this may cause a blockage of the boiler. Under such conditions we recommend you to repeat the ignition procedure until gas is delivered to the burner, briefly setting knob (1) to **R** position (ref. 1 figure 1).

### 4.1 Operation with Water Storage Tank Unit

The boiler water adjustment knob (Ref. 3 Figure 1) is only active when there is a Tank unit. In this case it is possible to adjust the domestic hot water temperature by turning the knob onto the required hot water setting.

With the summer/winter selector set to winter mode ❄️, when the water of the tank has reached the selected temperature, the boiler works automatically for the heating system (priority is given to the domestic hot water supply).

It is possible to exclude the sanitary mode just setting the knob (ref. 3 figure 1) to the minimum value, that corresponds to the anti-frost function of the tank.

With the summer/winter selector set to summer mode ☀️, the burner is alight and the tank’s pump works only when the temperature of the water inside the tank is less than the value set with the DHW knob.

## 5. Room temperature adjustment

The system must be equipped with a room thermostat (see the relevant regulations) to control the temperature in the rooms.

In case of temporary absence of a room thermostat, it will be possible, during initial lighting, to control the room temperature operating on the boiler water temperature regulation device (ref. 2 figure 1): in these conditions the central heating pump will continuously operate.

To increase the temperature turn the knob clockwise and anticlockwise to decrease it.

## 6. Turning off the boiler

To turn off the boiler correctly, follow the instructions described here below:

### **PARTIAL TURN OFF**

- Turn the selector switch (ref. 1 figure 1) on (0) and verify that the voltage lamp switches off (ref. 4 figure 1): in this way you cut off the electrical input to the boiler.

### **TOTAL TURN OFF**

- Close the gas cock if the boiler will not operate for a long time.

## 7. Filling the boiler

**Important:** Regularly check that the pressure displayed by the pressure gauge of the installation (for FiN models) or by the pressure gauge of the boiler (for Fi models) is 0.5 to 1 bar with the boiler stopped. In case the pressure is lower than 0,5 bar, fill the system by means of the filling tap that it must be present in the heating circuit.

We recommend you to carry out the filling operation very slowly in order to let off the air.

Do not fill the system when the boiler is still warm.

In case pressure drops occur frequently, the boiler has to be checked by a qualified Service Engineer.

## 8. Emptying the boiler

### 8.1. Emptying the boiler

To empty the boiler use the tap you find on the right side of the cast-iron exchanger after opening the upper door of the boiler and the door of room sealed.

To achieve this operation connect the tap with a flexible pipe to a drainpipe as it is here described:

- Connect the flexible pipe to the hose adapter of the drain tap of the boiler.
- Unscrew the nut of the drain tap.
- Open the draining valves of the radiators, starting, from the ones which are in the upper position.

---

**It is absolutely forbidden to empty the boiler through its safety valve.**

---

## 9. Prolonged standstill of the system - Frost protection

It is wise to avoid draining the entire heating system since frequently changing the water leads to harmful scale getting deposited in the boiler and in the heating elements.

If the heating system is not to be used during the winter, and when there is a risk of freezing, it is advisable to mix the water in the system with suitable antifreeze solutions intended for this specific use (e.g., propylene glycol associated with incrustation and corrosion inhibitors).

The boiler is equipped with an “antifreeze” function that, with system delivery temperatures under 5 °C, makes the burner operate until the delivery reaches a temperature of 30 °C.

The frost protection function is enabled if:

- Electrical supply to the boiler is on;
- Selector (1) is not in position (0);
- There is gas;
- The system water pressure is as required;
- The boiler is not blocked.

When there is a DHW tank the Boiler also has an “antifreeze” function for the domestic hot water. The electronic control will prevent it from falling under 5°C.

## 10. Safety device indicators - meaning

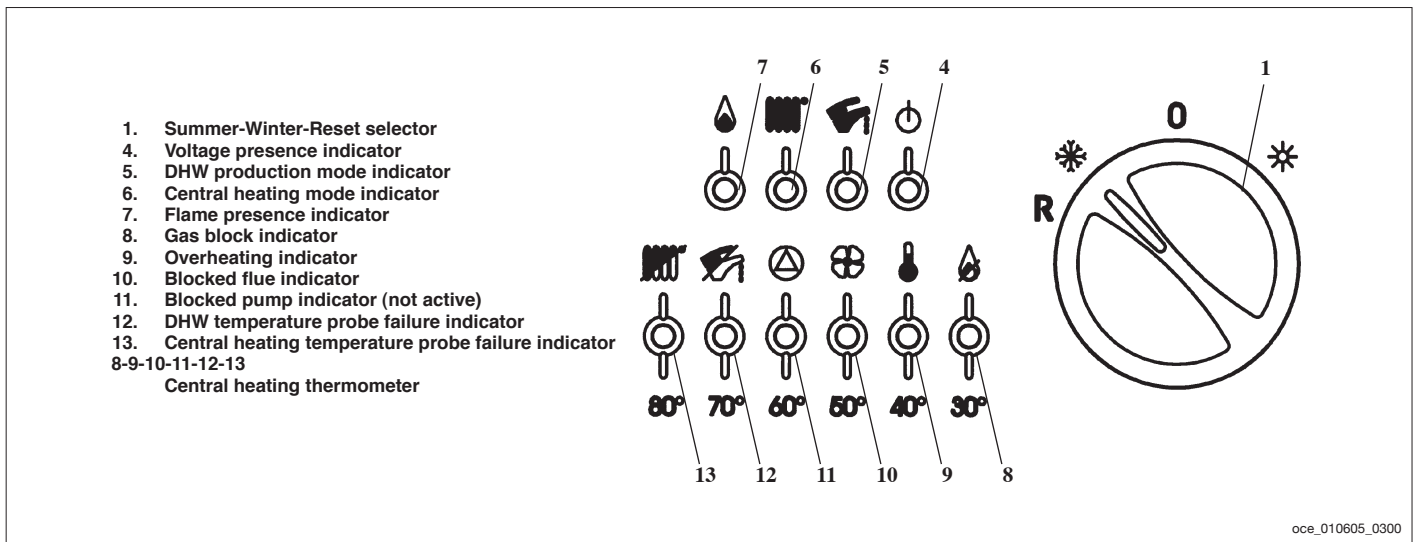

The lights 8÷13 display the temperature of the water in the central heating system (when not blinking).



The flashing warning (10)  no draught, is activated by an air - flue gas pressure switch in the event of:

- total or partial obstruction of the flue outlet or duct;
- fan jammed;

In these conditions the boiler stays on standby (burner off) and only after removing the cause of the warning will normal operation be automatically restored.

The blinking of light (9)  signs the safety thermostat operation and indicates that the water of the central heating circuit has reached very high levels of temperature due to an anomaly in the boiler's regulation devices.

In this condition the boiler blocks and the light (9) continues to blink. Once you have solved the problem, to re-establish the normal working condition, rotate the knob of the selector (1) temporarily in position **R**, after waiting for a lowering of at least 20°C of the heating flow water temperature.

When the light (9)  is blinking, the light (8)  will be blinking as well.

---

**It is forbidden to disable these safety devices**

---

The gas block light (8)  starts to blink when a lack of gas or an incomplete ignition of the burner occurs.

In this condition the boiler stays in a safety block.

To re-establish the normal working condition of the boiler, rotate the selector knob (1) temporarily in position **R**.

---

**In case of repeated operations of these safety devices, contact the Qualified Service Engineer.**

---

## 11. Gas conversion

These boilers are adjusted for natural gas but can be converted to work with LPG.

Any gas conversion must be carried out by Qualified Service Engineer.

## 12. Servicing instructions

To maintain an efficient and safe operation of your boiler, it has to be checked by a Qualified Service Engineer at the end of every season.

Careful servicing will ensure economical operation of the system.

Do not clean the outer casing of the appliance with abrasive, aggressive and/or easily flammable cleaners (i.e. gasoline, alcohol, and so on). Always isolate the electrical supply to the appliance before cleaning it.

# Instructions pertaining to the installer

The following remarks and instruction are addressed to Service Engineers to help carry out a faultless installation.

Instructions regarding lighting and operation of the boiler are contained in the 'Instructions pertaining to the user's section'.

## CAUTION:

- When moving the unfastened appliance, the door of the instrument panel may accidentally open and get damaged by knocking against other objects. If installation requires special handling of the appliance, it is recommended to secure it with adhesive tape.
- The parts of the packing (plastic bags, polystyrene, etc.) must not be left within reach of children as they are potential sources of danger.

## 1. Overall dimensions

### 1.230 FiN, 1.300 FiN Models

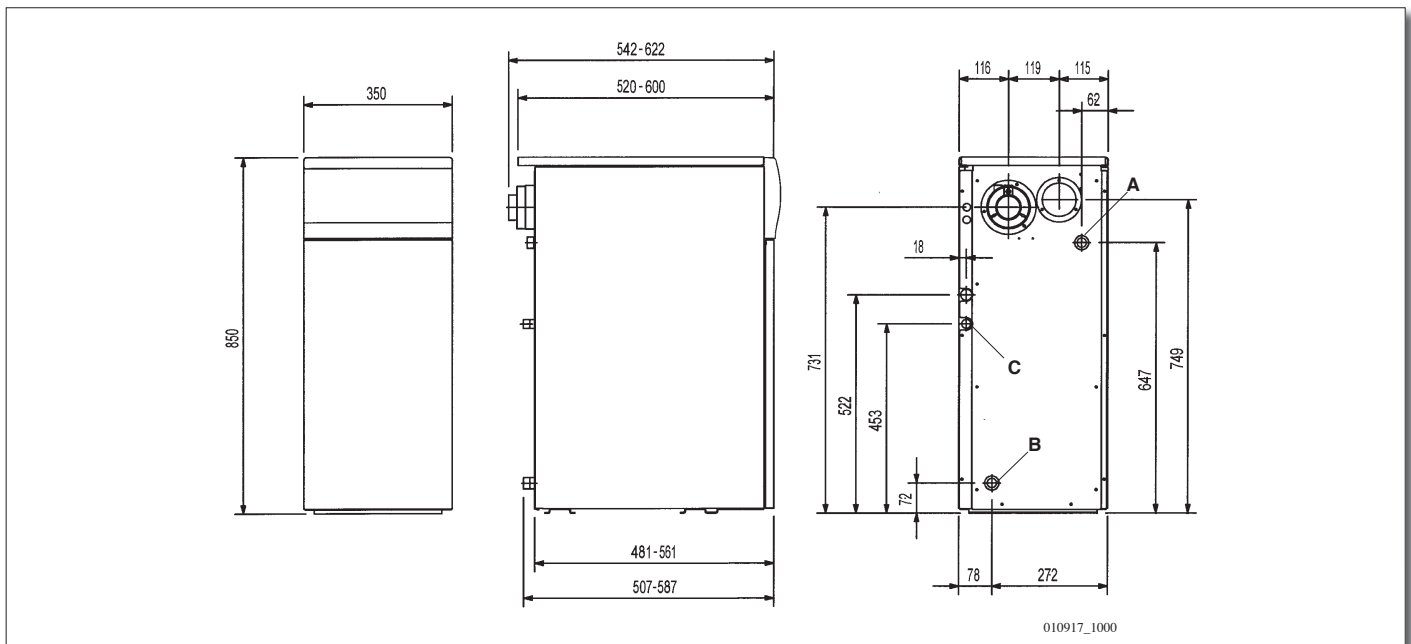



## 1.230 Fi, 1.300 Fi models

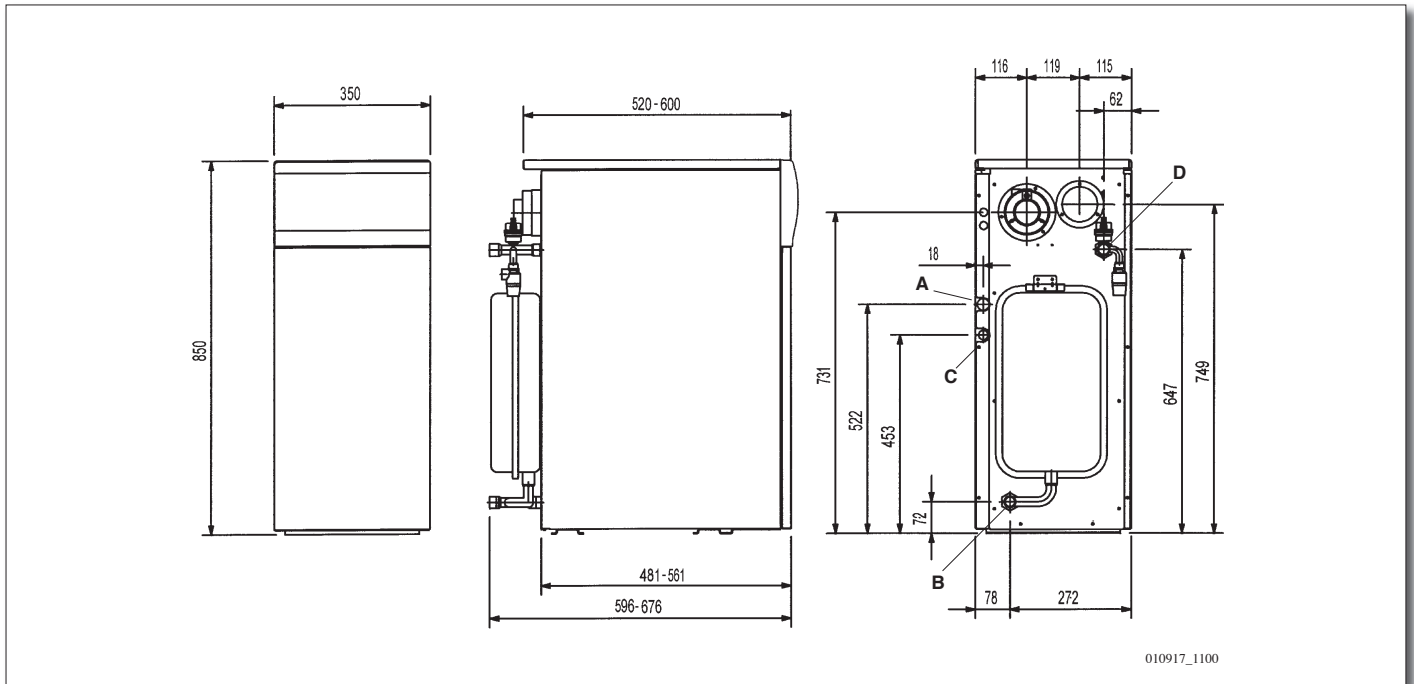

**TABLE I**  
FiN models without plumbing accessories

boiler models	dimensions			connections		water cont.	
	height H mm	width mm	depth L mm	delivery A	return B	gas C	l
1.230 FiN	850	350	542	3/4" m	3/4" m	1/2" m	11,8
1.300 FiN	850	350	622	3/4" m	3/4" m	1/2" m	14,6

**TABLE II**  
Fi models with plumbing accessories

boiler models	dimensions			connections		water cont.		
	height H mm	width mm	depth L mm	delivery A	return B	gas C	DHW tank outlet D	l
1.230 Fi	850	350	596	3/4" m	3/4" m	1/2" m	3/4" F	11,8
1.300 Fi	850	350	676	3/4" m	3/4" m	1/2" m	3/4" F	14,6

## 2. General information

This boiler must be installed by a qualified service engineer.

### Important:

- Connect the inlet gas pipe of the boiler to the gas distribution network using a metallic pipe and install a gas cock before the boiler.
- The boiler can be used with any type of radiators, convectors, single or double pipe. Sections of the system will be, in any case, calculated according to the normal methods, keeping in mind of the hydraulic resistance performances (see paragraph 18).
- In case of external installation, avoid that the boiler is directly exposed to atmospheric agents as wind, water, frost, which can prejudice the operation and the safety of the boiler. Non-observance of such

prescription involves the immediate loss of the guarantee. For this reason we suggest the creation of a technical space, protected from bad weather.

- Do not leave any parts of the packaging (plastic bags, polystyrene, etc.) within children's reach as they are a potential source of danger.
- Initial ignition of the boiler must be carried out by Qualified Service Engineer.

Non-observance of such prescription involves the immediate loss of the guarantee.

### 3. Instruction prior the installation

This boiler is designed to heat water at lower than boiling temperature at atmospheric pressure. The boiler must be connected to a central heating system in compliances and heat output.

Ensure the following operations are carried out:

- Careful washing of all the pipes of the system to remove possible threat or welding residual and solvents.
- Careful checking that the boiler is fit for operation with the type of gas available. For more details see the label on the packaging and the serial number label on the appliance.
- Careful checking that, in case the flue has been connected to pre-existing flue ducts, thorough cleaning has been carried out in that residual combustion products may come off during operation of the boiler and obstruct the flue duct thus engendering dangerous situations.

### 4. Installation

After determining the exact location of the boiler, installation should be performed taking account in particular of easy maintenance (the front door must open).

To evaluate the weight the boiler exerts on the floor it is necessary to take account of the weight of the water too (see table I or II).

The floor must not be made of flammable materials. If necessary, insert a panel made of non-flammable, insulating material under the bottom of the boiler.

#### 4.1. Connecting to the Heating System

Install the heating system starting from the position of the connections (dimensions and connections are given in table I or II). It is advisable to install two shut-off cocks on the heating circuit delivery and return lines so it is possible, in the event of major work, to work without having to drain the entire heating system.

In addition, it is necessary to install an automatic loading unit and three-piece joints, on both the water and gas connections.

**The FiN models have no expansion tank and safety valve; these devices must be present in the system and suitably sized for the heating capacity and the capacity of the system itself.**

Zone systems equipped with motorized valves must have a bypass connection between the boiler delivery and return with an adjustable overflow valve in between (the bypass is not necessary in systems equipped with zone pumps).

The boiler is drained by using the drain cock on the right of the cast-iron shell (remove the panel of sealed room).

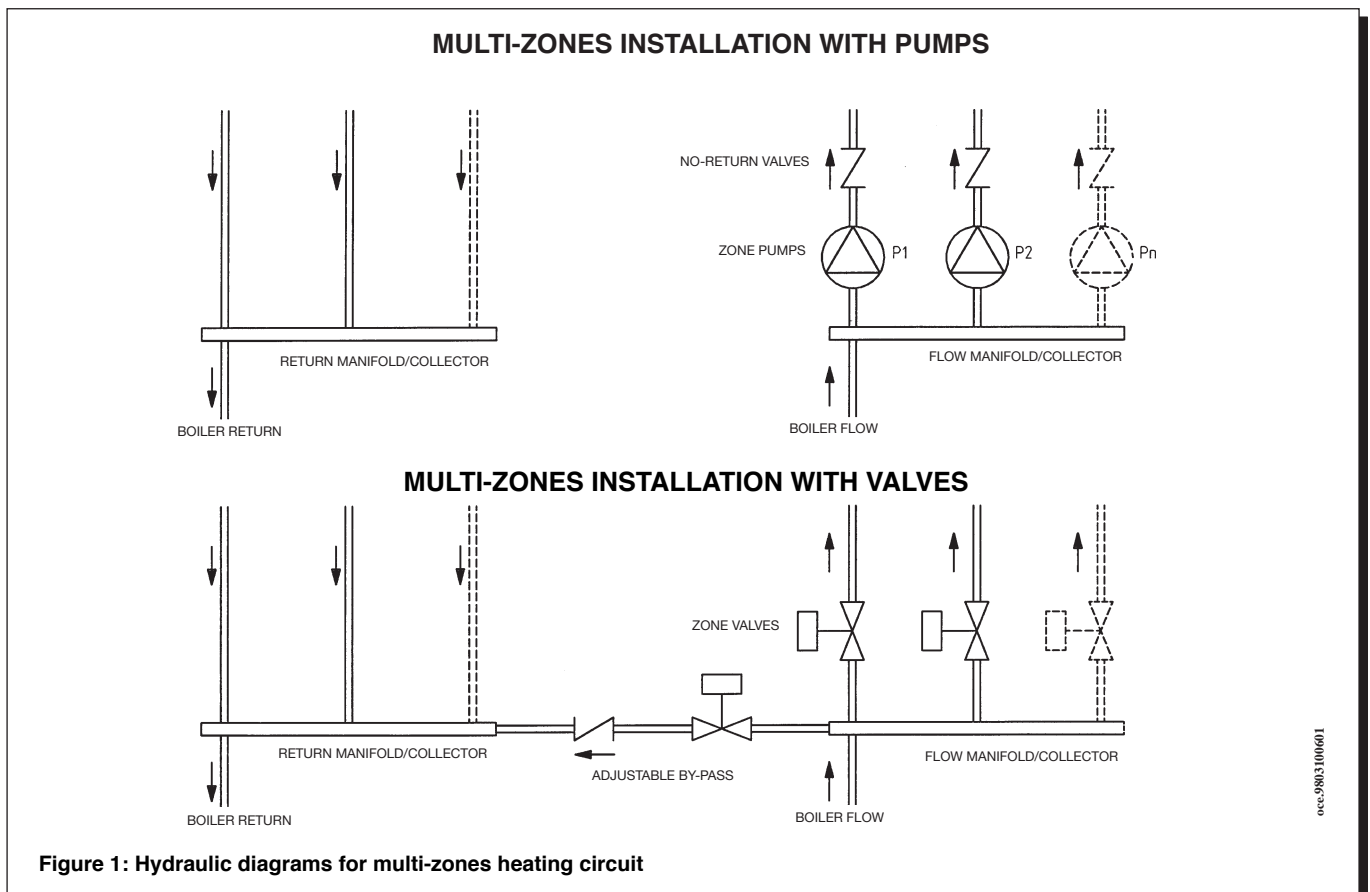

occ.9803.100601

Figure 1: Hydraulic diagrams for multi-zones heating circuit

## 4.2 Gas connection

The gas installation and commissioning must be performed by a specialized technician in compliance with current regulations.

Connect the boiler gas supply pipe to the gas mains by means of a metal pipe, inserting a stopcock upstream from the boiler.

The dimensions and height of the boiler's gas pipe connection are given in table I or II.

## 4.3 Installing the inlet - outlet ducts

**SLIM** Fi forced flow gas boilers can be installed easily and flexibly thanks to the accessories supplied, which are described further on.

The boiler is originally fitted for connection to a vertical or horizontal, coaxial inlet - outlet duct. Thanks to the splitter accessory it is possible to use separate ducts too.

**Only accessories supplied by the manufacturer must be used for installation!**

type of ducts	max outlet duct length without terminal	reduction in length to insert 90° bend	reduction in length to insert 45° bend	flue terminal diameter	external duct diameter
coaxial	5 m	1 m	0,5 m	100 mm	100 mm
twin horizontally	10 m	0,5 m	0,25 m	-	80 mm
twin vertically	6 m	0,5 m	0,25 m	133 mm	80 mm

### 4.3.1 coaxial (concentric) inlet - outlet duct

This type of duct can be used to discharge flue gases and draw in air for combustion both outside the building and in LAS-type flues.

The 90° coaxial bend enables connecting the boiler to the inlet - outlet ducts in any direction since rotation is possible through 180°. It can also be used as an additional bend in combination with the coaxial duct or 45° bend.

The boiler is supplied with a diaphragm for concentric pipes.

(\*) The concentric diaphragm should only be inserted when the length of the outlet duct is less than 1 metre.

When discharging outside, the inlet - outlet duct must protrude from the wall by at least 18 mm to permit positioning the aluminium rose and sealing it in order to prevent moisture getting inside.

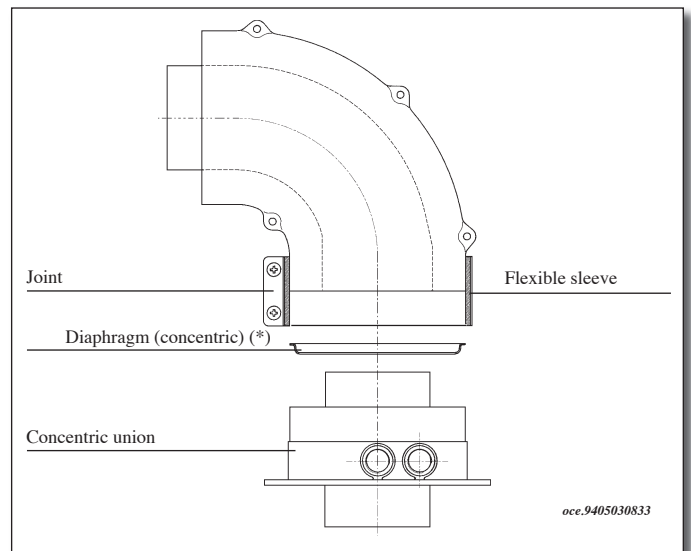

The minimum slope of these ducts towards the outside must be 1 cm per metre in length.

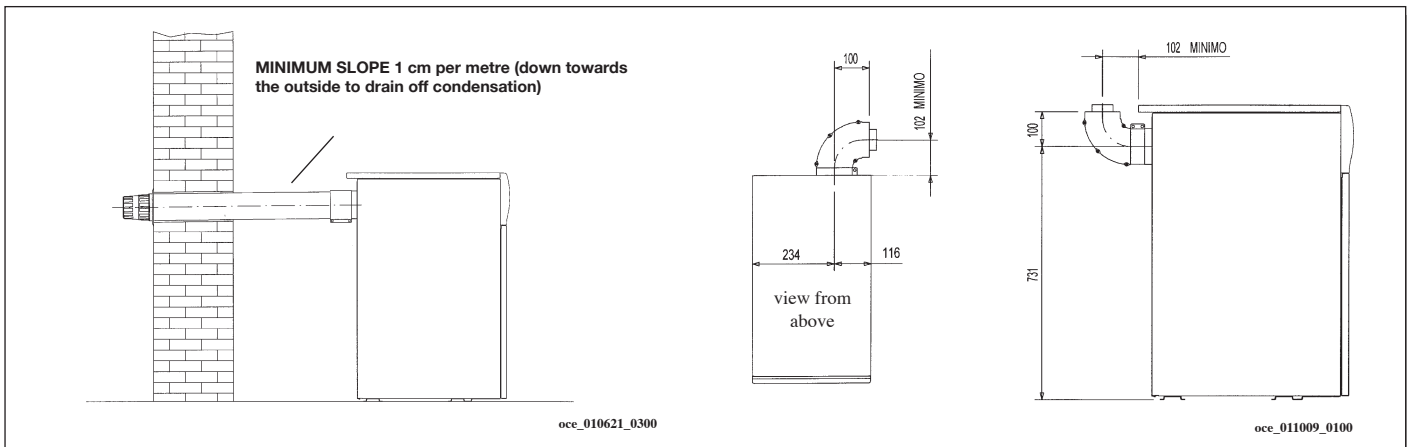

Adding a 90° bend shortens the total length by 1 metre.  
Adding a 45° bend shortens the total length by 0.5 metres.

examples of installation with horizontal ducts

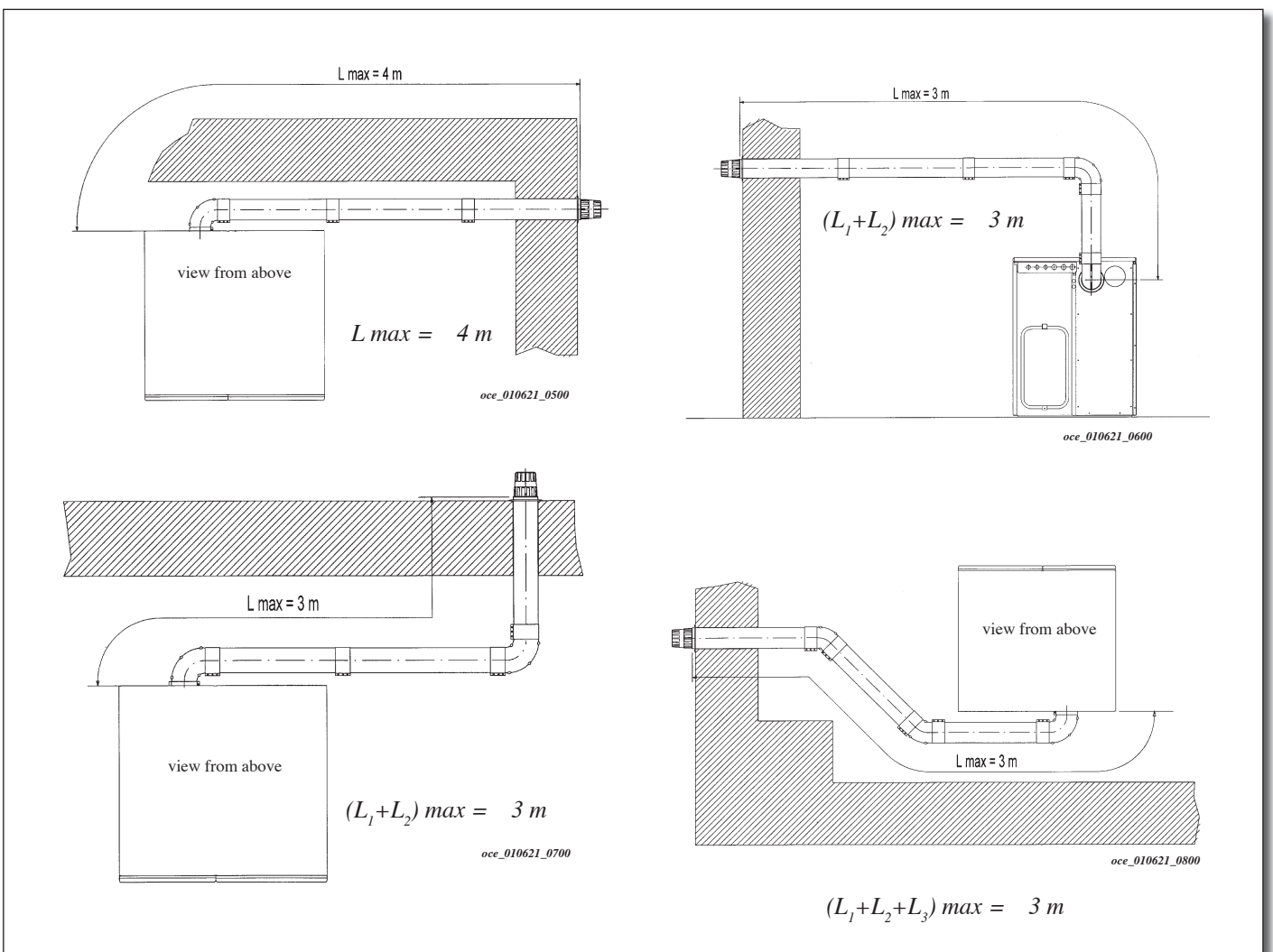

### examples of installation with LAS-type flues

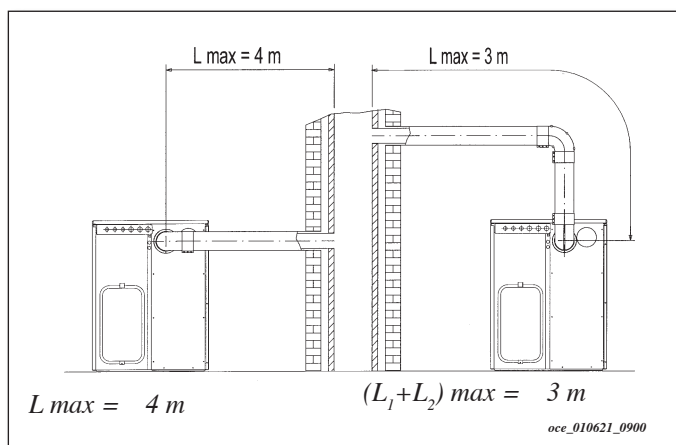

### examples of installation with vertical ducts

Installation can be performed either with a pitched roof or with a flat roof using the stack and the special tile and sheath available on request.

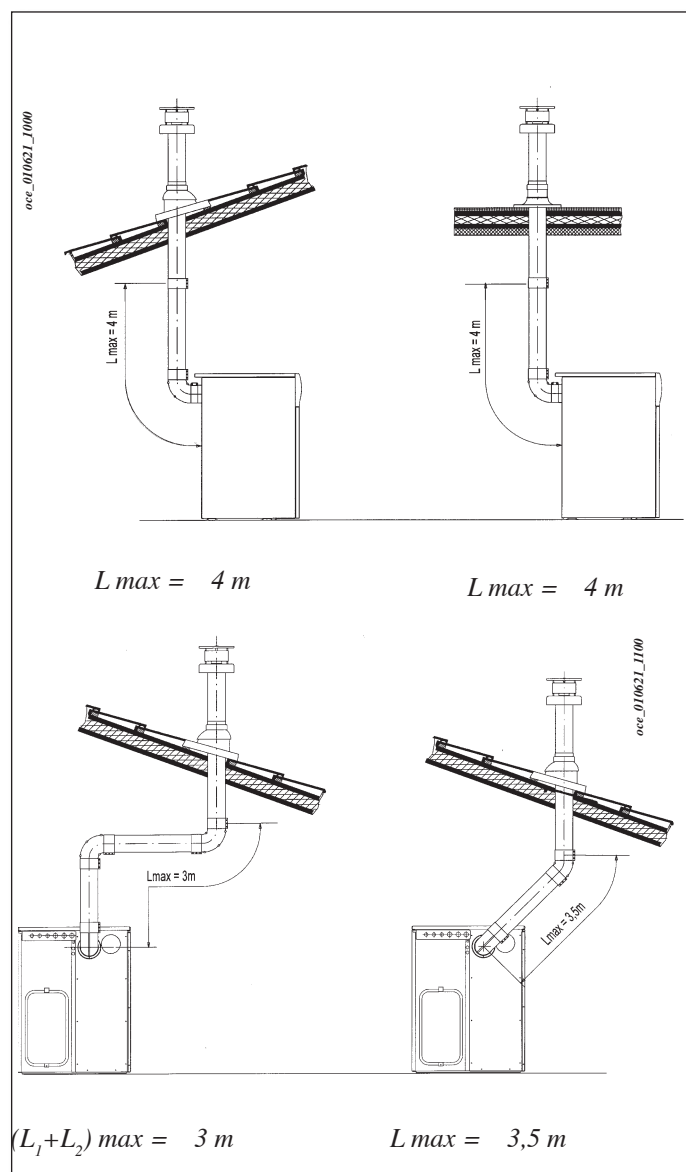

For more detailed instructions on how to fit the accessories, please refer to the technical notes provided with the accessories.

### 4.3.2 twin pipe ducts

This type of duct can be used to discharge flue gases both outside the building and in single flues. The air for combustion can be drawn in at different places to those for discharge.

The splitter is an accessory comprising an exhaust reduction coupling (100/80) and a shutter air intake coupling.

The seal and the screws of the air intake coupling are the ones removed beforehand from the plug.

For more detailed instructions on how to fit this accessory, please refer to the technical notes provided with it.

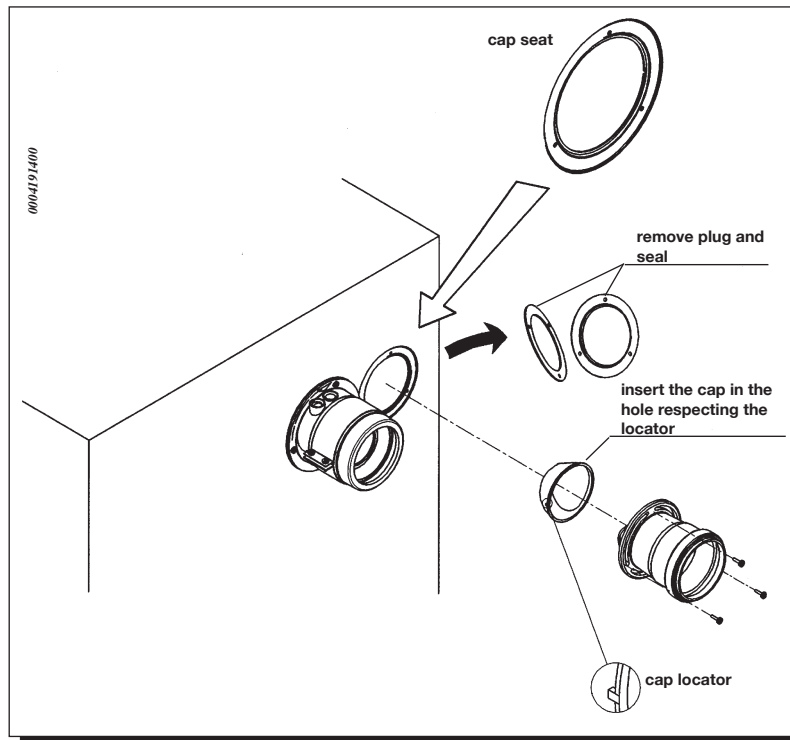

### Air register adjustment for split outlet

This register needs to be adjusted to optimize efficiency and combustion parameters. By turning the air intake coupling you can adjust the excess air appropriately according to the total length of the ducts for the combustion air intake and outlet.

**The air intake coupling must be fitted with the pointer facing the inside of the boiler (see figure).**

For better optimization it is possible, using an analyzer for the products of combustion, to measure the content of CO<sub>2</sub> in the flue gases at the highest heating capacity and gradually adjust the air register in order to obtain a CO<sub>2</sub> measurement of:

- 6.5% with natural gas G.20
- 7% with liquid gas G.30-G.31

The 90° bend enables connecting the boiler to the inlet and outlet ducts in any direction since rotation is possible through 180°. It can also be used as an additional bend in combination with the duct or 45° bend.

Adding a 90° bend shortens the total length by 0.5 metres.  
 Adding a 45° bend shortens the total length by 0.25 metres.

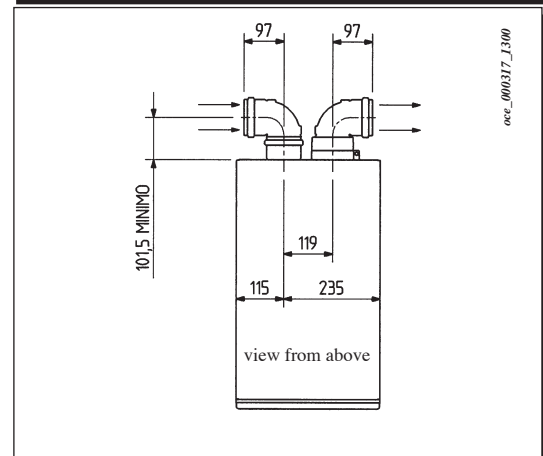
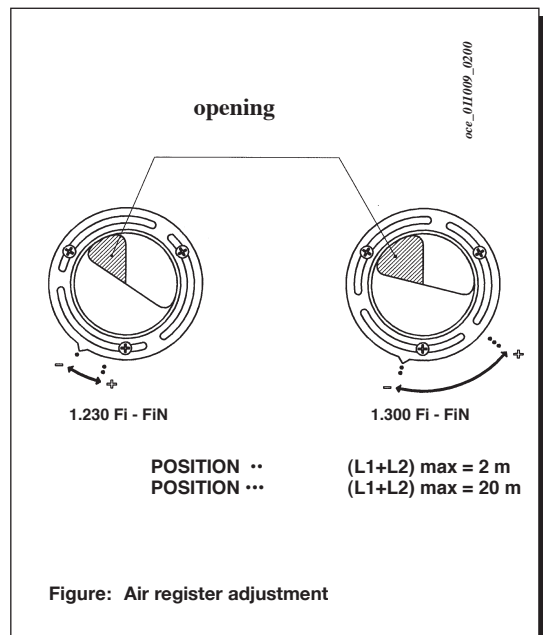

examples of installation with twin pipe horizontal ducts

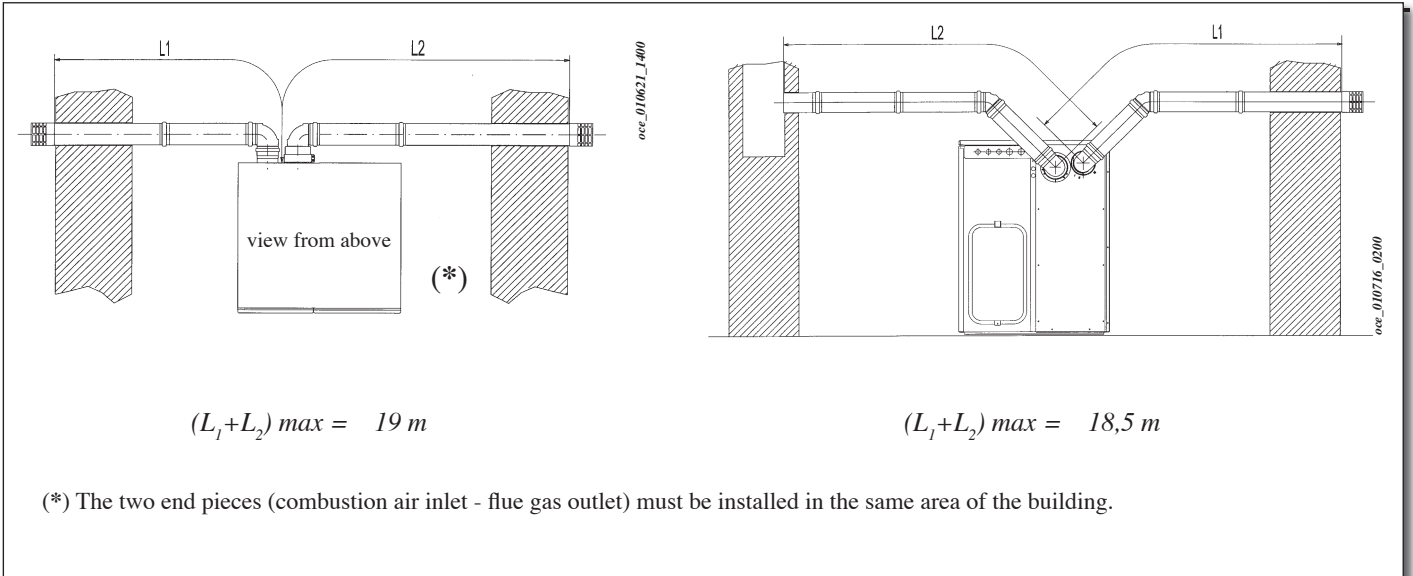

The outlet pipe must never be any longer than 10 metres calculated with a 90° bend. For lengths greater than 6 metres, it is necessary, for the entire length of the outlet duct, to use insulated pipes and bends so that the loss of temperature along the duct is limited.

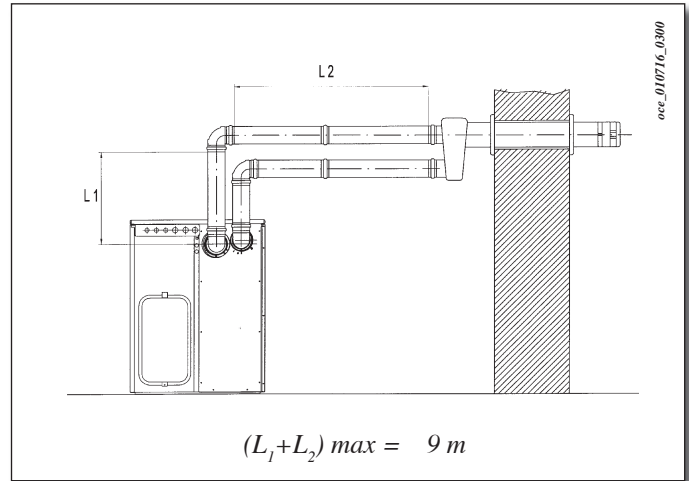

examples of installation with twin pipe vertical ducts

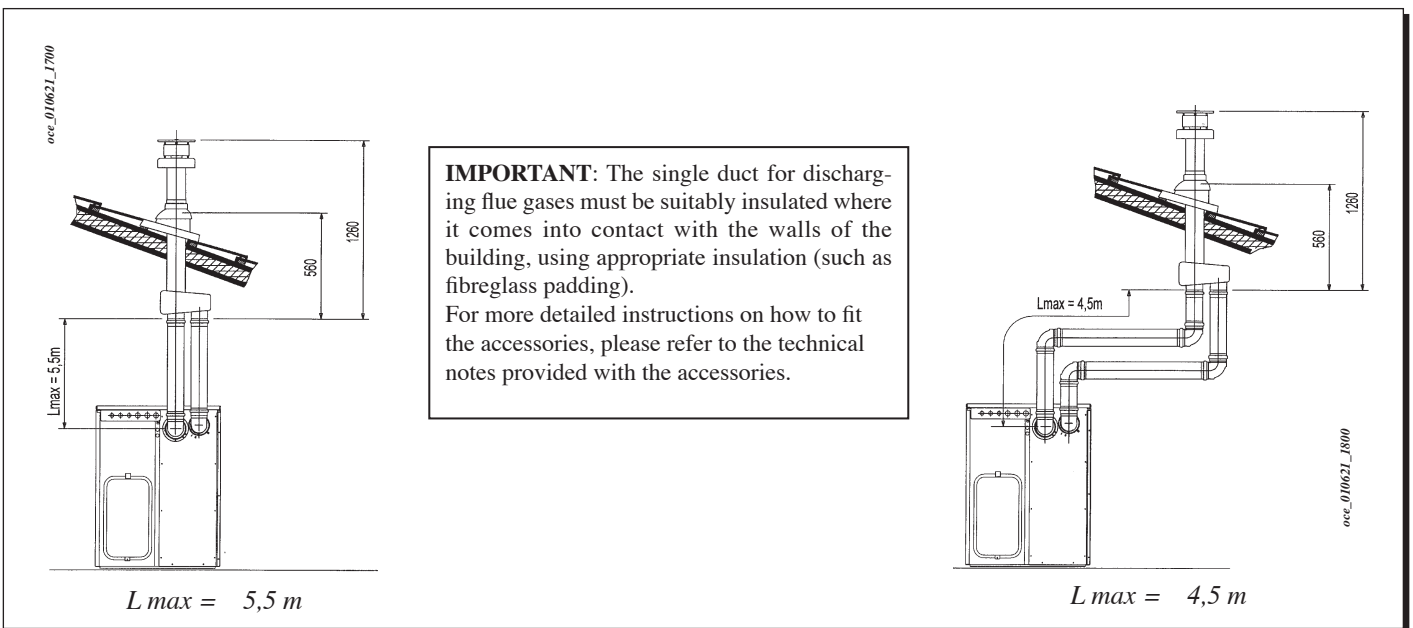

## 5. Electrical connection

Boilers are delivered with electrical connections and electrical power supply cable.

Electrical safety of the appliance is guaranteed only by correct grounding, in compliance with the applicable laws and regulations.

Connect the boiler to a 230 V mono-phase + ground power supply by means of three-pin cable supplied with it and make sure you connect polarities L (live) and N (neutral) correctly.

Use a double-pole switch with a contact separation of at least 3mm in both poles.

In case you replace the power supply cable, fit a "HAR H05-VV-F" 3x0.75 mm<sup>2</sup> cable with a diameter of 8 mm max.

### 5.1. Access to the power supply terminal block

- Isolate the electrical supply to the boiler by means of the double-pole switch;
- Remove the cover pulling it up;
- Open the upper panel pulling on the upper corners of the boiler;
- Unscrew the two screws securing the control board to the boiler;
- Rotate the control board;
- Unscrew the screws securing the control board to the boiler;
- A 2A fast-blowing fuse is incorporated in the power supply terminal block (fig. 2).

(L) = LIVE WIRE brown  
 (N) = NEUTRAL WIRE blue  
 (⊕) = EARTH yellow-green  
 (1) (2) = Room thermostat contacts

### 5.2. Pump connection (FiN models only)

These models are sold without a circulation pump. If you want to operate the system pump directly from the boiler, the connection operations are the following:

- Cut off power to the boiler with the two-pole switch.
- Open and remove the front door of the boiler and the cap.
- Pass the pump supply cable through the cable glands (use a harmonized cable "HAR H05 VV-F" 3x0.75 mm<sup>2</sup> with a maximum diameter of 8 mm). Access the wiring board as described in the paragraph: "Electrical connection Accessing the supply terminal block."
- Make the electrical connection following the diagram in the figure.

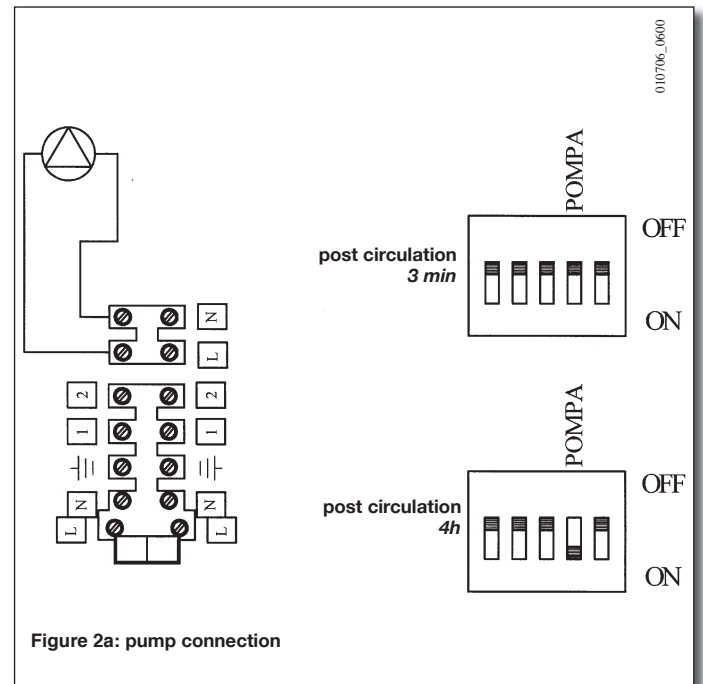

Figure 2a: pump connection

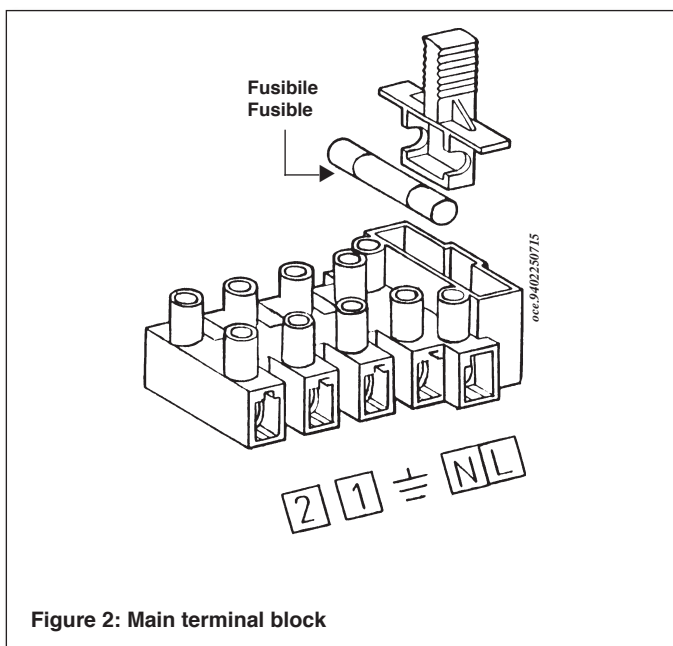
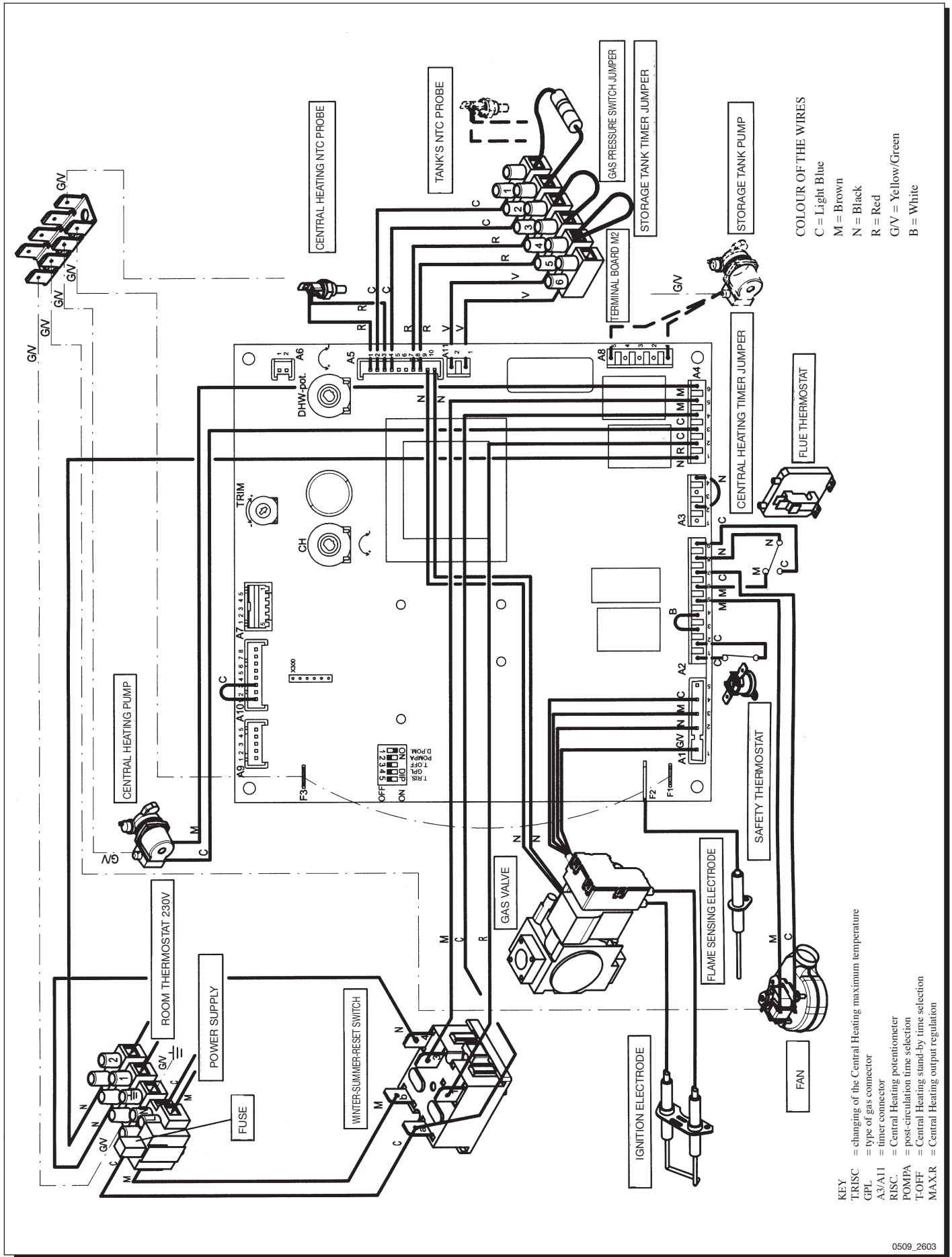

Figure 2: Main terminal block



# 6. Electrical diagram



# 7. Room thermostat connection

- Reach the terminal board as described in paragraph 5.1.
- Take off the jumper from terminals (1) and (2) of the main terminal board (see electrical diagram in paragraph 6).
- Insert the duplex cable through the cable clamp of the boiler and connect it to the two terminals (use a “HAR H05-VV-F” 2x0.75 mm<sup>2</sup> cable with a diameter of 8 mm max).

### Multi- zones installation

In case of a multi-zones installation, the room thermostats have to be connected following the diagram of figure 3. Zone-valves or zone-pumps have to be electrically supplied separately from the boiler as described in the electrical diagram of figure 3.

### With QAA73 climatic regulator

The zone valve and zone pump controlled by the QAA73 have to be electrically supplied following the diagram in figure 3.

### Case 1: Installation without external probe

The heating flow temperature for the single zones must be set by means of the Central Heating circuit temperature control device of the boiler control panel (knob 2). In case of simultaneous demand from the main zone, controlled by the QAA73, and one of the other zones, the heating flow temperature will be the maximum value between the one processed by the QAA73 and the one set on the boiler control panel (knob 2).

### Case 2: Installation with external probe

The heating flow temperature for the single zones is the one processed by the electronics (PCB) of the boiler according to the external temperature and the set heating curve as described in the section “External probe connection”.

In case of a simultaneous demand from the main zone, controlled by the QAA73, and one of the other zones, the heating flow temperature will be the maximum value between the one processed by the QAA73 and the one processed by the boiler PCB.

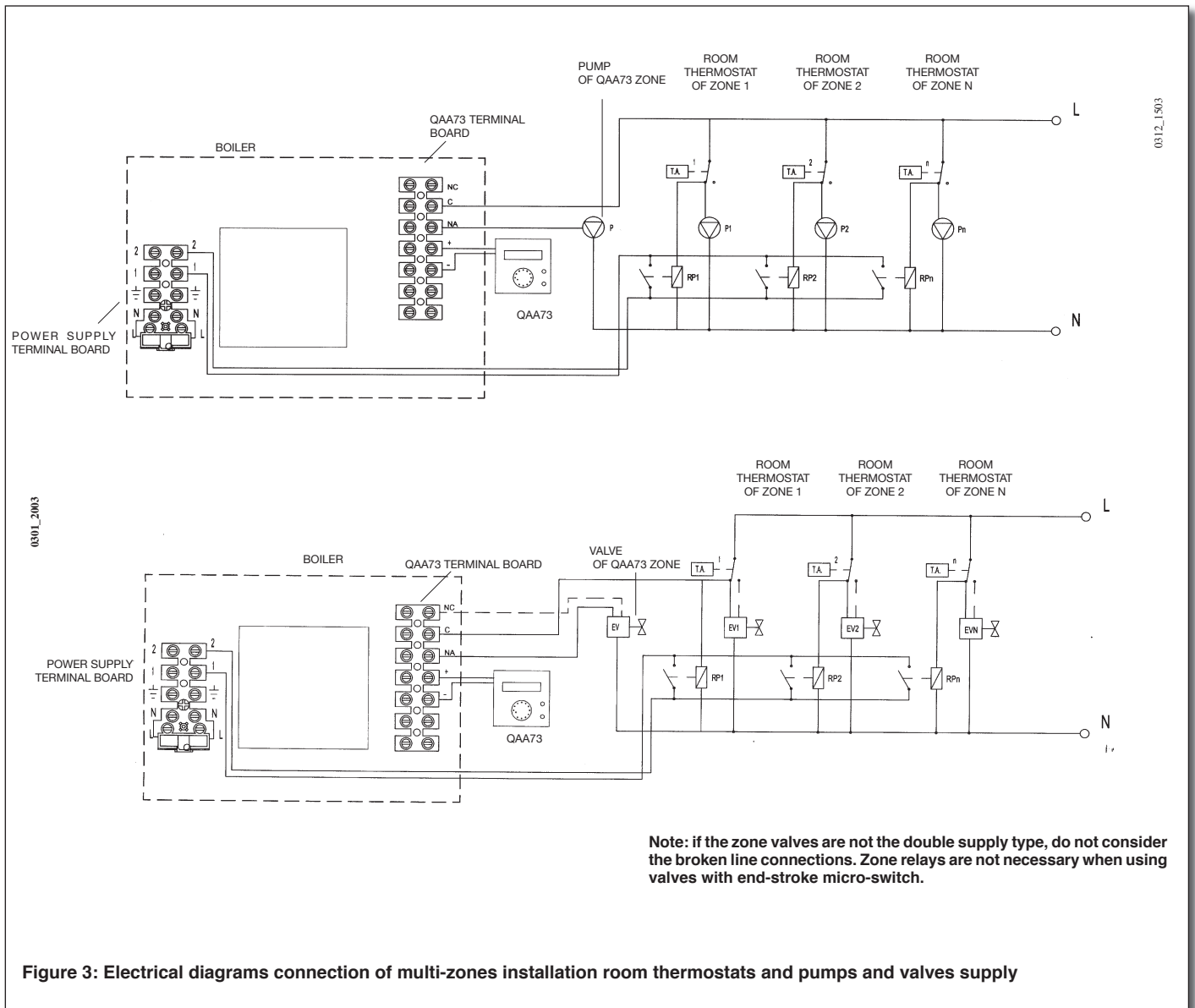

Figure 3: Electrical diagrams connection of multi-zones installation room thermostats and pumps and valves supply

## 8. Connecting a programming timer (accessory on demand)

Boilers are arranged for the connection of a programming timer (daily or weekly), which diameter is 62 mm, to program the Central Heating and the DHW operation.

To install the timer, see the following instructions:

### Central Heating timer

- Reach the inside of the electrical box as described on paragraph 5.1: "Access to the power supply terminal block".
- Cut with a cutting nippers the box cover anchorage (pre-cut) on the left side of the control panel.
- Install the timer, securing the screws.
- Remove the yellow jumper of the A3 connector on the boiler PCB (contacts 2-4) and connect the "common and normally open" contacts of the timer to the terminal board.
- Connect the motor contacts of timer to the A3 connector of the boiler PCB (contacts 1-3).

If a battery-run timer is used, leave contacts (1-3) of A3 connector free.

For the right connection of the timers see also the electrical diagram of figure 4.

### Domestic Hot Water timer (WITH WATER STORAGE TANK)

- Remove the yellow jumper of the M2 terminal block on the boiler (contacts 5-6) and connect the "common and normally open" contacts of the timer to the terminal board.

Insert the connecting cable through a cable clamp of the boiler. free.

For the right connection of the timers see also the electrical diagram of figure 4.

**For the SLIM UB 80 – 120 boiler unit do not take account of these connections, follow the instructions provided with the appliance.**

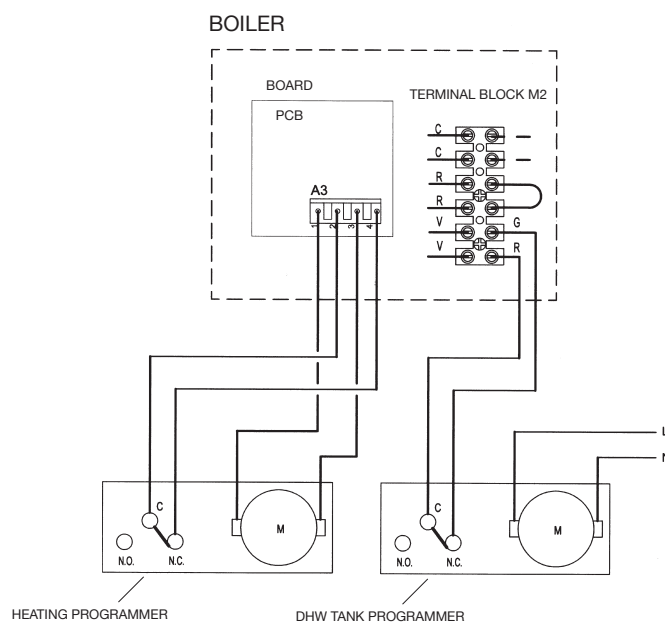
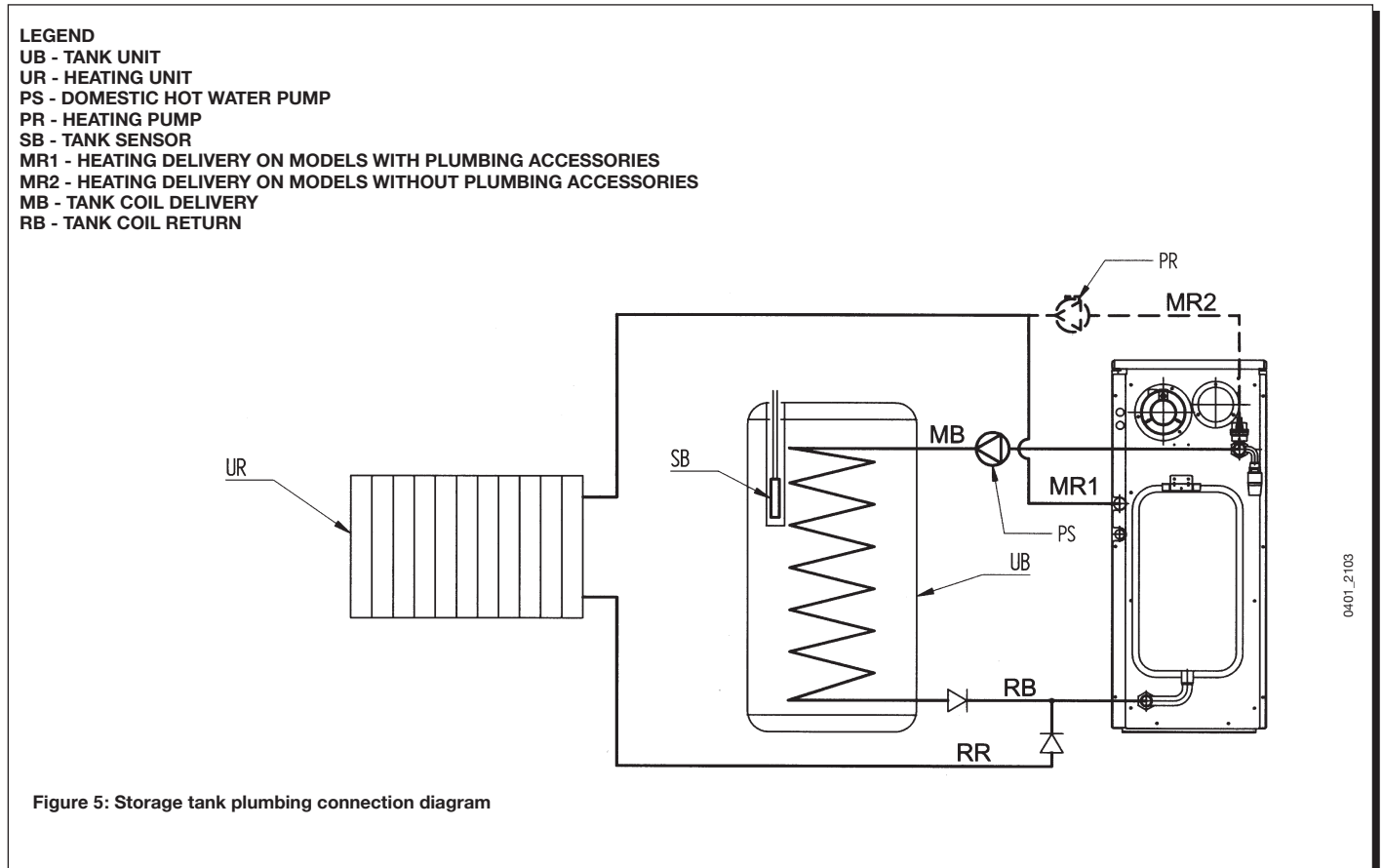

Figure 4: Programmer clock connection

## 9. Domestic hot water tank connection

The boilers are fitted to be connected to a boiler unit to generate domestic hot water. The boiler unit may be supplied by **BAXI** or be acquired on the market.

For the plumbing connection, follow the sketch shown in Figure 5.



For the electrical connection, depending on the case, follow the instructions given here.

## 9.1 Trade tank not supplied by BAXI

(the boiler must have a thermostat pocket of diameter greater than 7 mm)

For this application it is necessary to use the “domestic hot water sensor - pump connection cable” kit supplied as an accessory.

To connect the boiler and the tank unit correctly, proceed as follows, referring to Figure 6 too:

- Get into the electric box as described in paragraph 5.1: “Electrical connection Accessing the electric box.”
- Connect the 5-pole cable supplied in the Kit to the A8 connector of the electronic circuit board and to terminals 1 and 2 of the Terminal Block M2 (black and red cable) after removing the electric heating element. Lastly, connect the ground Faston connector.
- Move one of the two ends of the yellow jumper “Domestic Hot Water Programmer” from terminal 5 to terminal 6 of the terminal block M2 (domestic hot water function activation).
- Pass the cable through the cable glands and secure the 6-pin connector on the rear of the boiler using the screws provided in the kit, after taking the covers off the connector.

### Domestic Hot Water Sensor

- Connect the domestic hot water sensor to terminals T<sub>1</sub> and T<sub>2</sub> of the 6-pin connector and insert it into the tank pocket (thermostat sensor carrier).

### Tank Pump

- Connect the boiler pump to the terminals (L<sub>1</sub> - N -  $\frac{1}{2}$ ) of the 6-pin connector using a harmonized cable “HAR VV - F” 3 x 0.75 mm<sup>2</sup>.

Close the covers of the 6-pin connector.

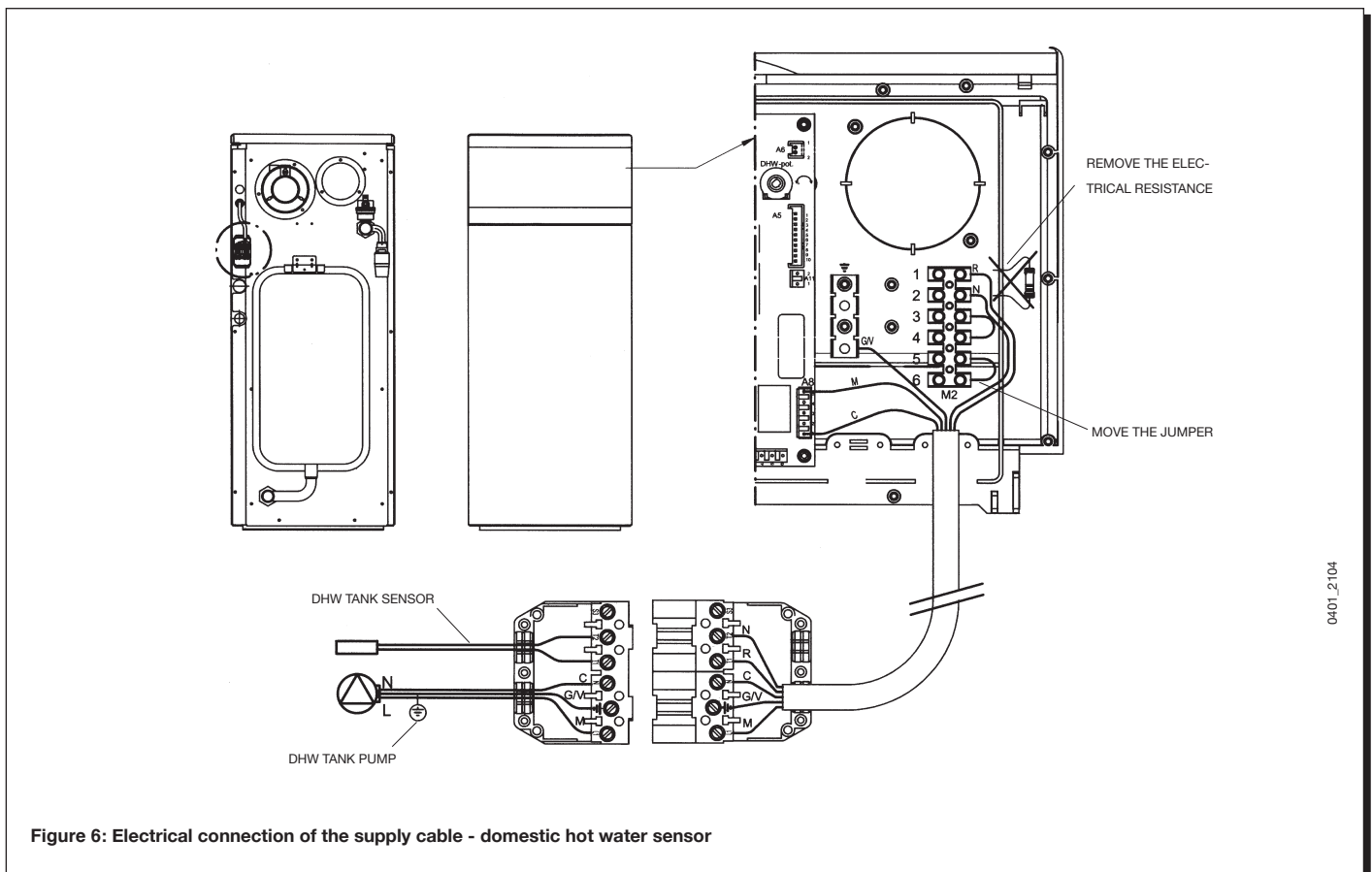

## 9.2 Tank Unit BAXI SLIM UB 80 –120

To connect the boiler and the tank unit correctly, proceed as follows, also referring to the instructions provided with the boiler unit:

- Get into the boiler's electric box as described in paragraph 5.1: "Electrical connection Accessing the electric box."
- Connect the 2-pin cable leaving the boiler unit to terminals 5 and 6 of the Terminal Block M2 (grey - red cable), after removing the yellow jumper. Pass the cable through the boiler cable glands.

### Tank Pump

- Connect the tank pump to the terminals (37) and (39) of the wiring board of the tank unit (use a harmonized cable "HAR VV – F" 3 x 0.75 mm<sup>2</sup>).

**Caution: The domestic hot water adjustment knob (Ref. 3 Figure 1) must remain in the maximum position.**

The domestic hot water adjustment must be made on the knob in the tank unit.

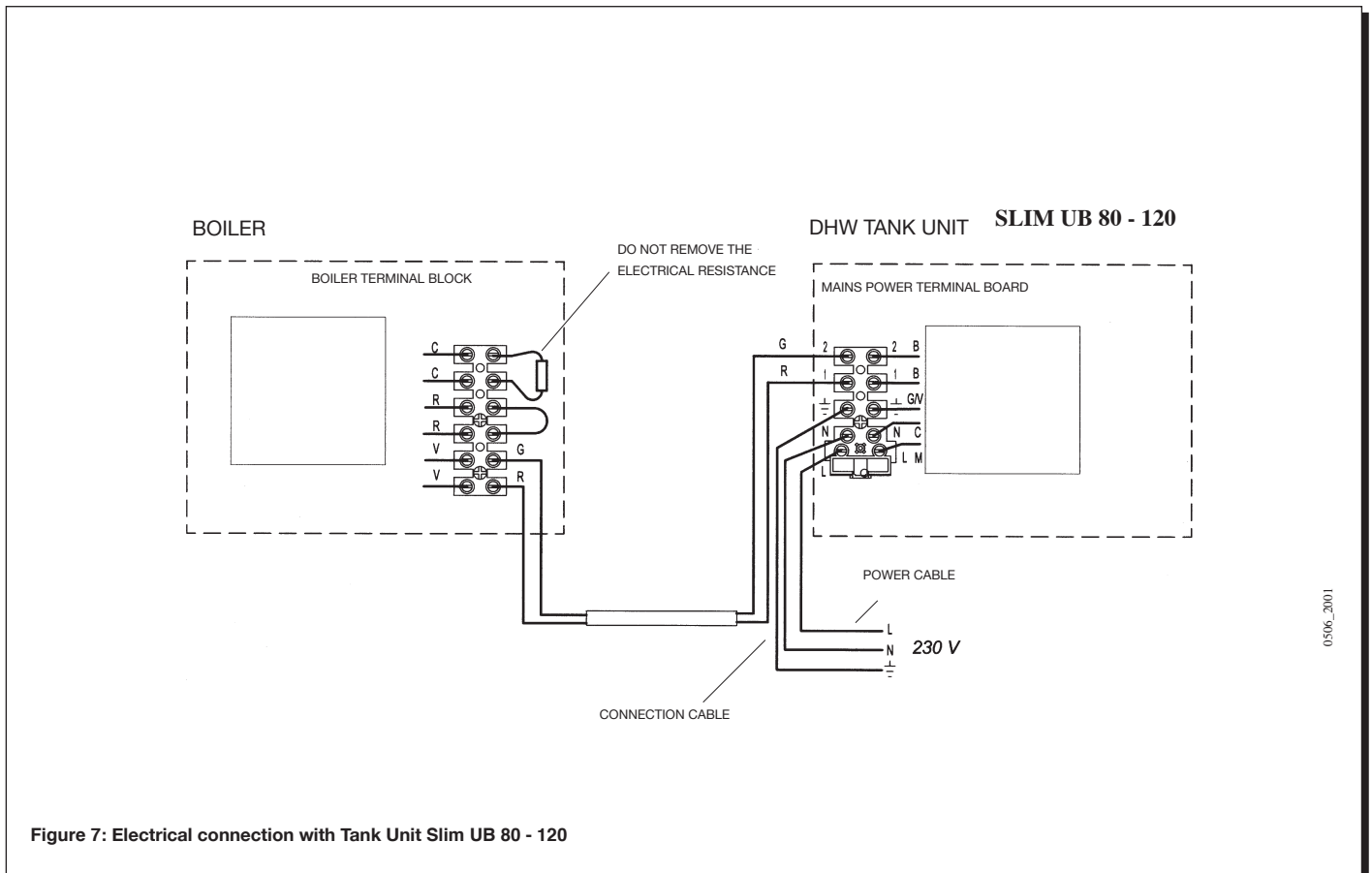

### 9.3 Tank Unit BAXI SLIM UB 80 – 120 INOX (STAINLESS STEEL)

To connect the boiler and the tank unit correctly, proceed as follows, also referring to the instructions provided with the boiler unit:

- Get into the electric box as described in paragraph 5.1: “Electrical connection Accessing the electric box.”
- Connect the 5-pole cable supplied with the tank unit to the A8 connector of the electronic circuit board and to terminals 1 and 2 of the Terminal Block M2 (black - red cable) after removing the electric heating element. Lastly, connect the ground Faston connector (see Figure 6).
- Move one of the two ends of the yellow jumper “Domestic Hot Water Programmer” from terminal 5 to terminal 6 of the terminal block M2 (domestic hot water function activation).
- Pass the cable through the cable glands and secure the 6-pin connector on the rear of the boiler using the screws provided, after taking the covers off the connector (Figure 6).

#### Domestic Hot Water Sensor

- Using the 2-pole cable supplied, connect the terminals ( $T_1$  and  $T_2$ ) of the 6-pin connector with the 2-pin terminal block of the tank unit (Figure 8).

#### Boiler Pump

- Connect the tank pump to the terminals ( $L_1 - N - \text{⏏}$ ) of the 6-pin connector using a harmonized cable “HAR VV – F” 3 x 0.75 mm<sup>2</sup> (Figure 8).

Close the covers of the 6-pin connector.

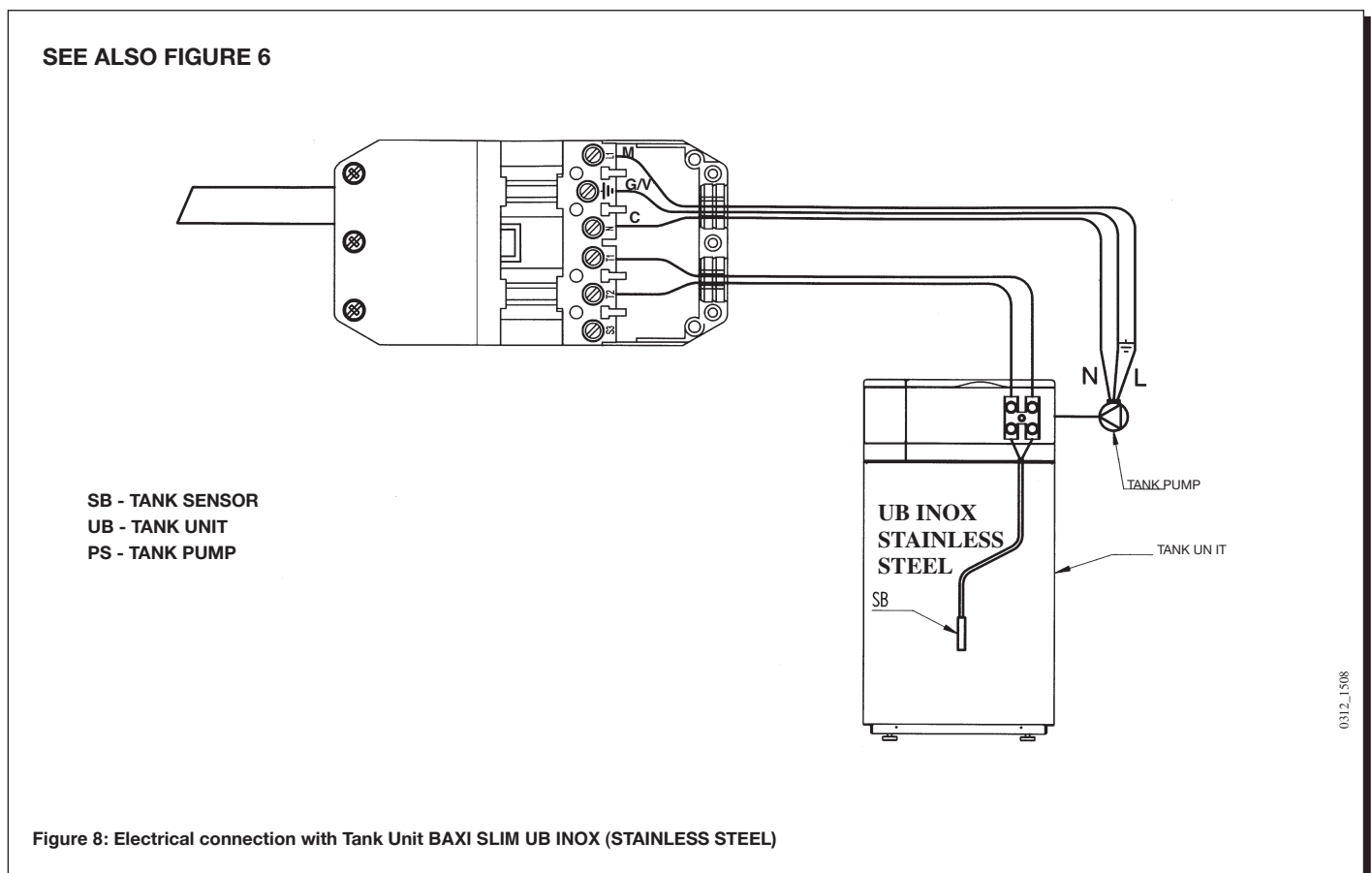

## 10. Connection of the external probe (accessory on demand)

The boiler is prearranged for the connection of an external probe, supplied as accessory on demand, which automatically regulates the heating flow temperature depending on the outside temperature and on the set Kt coefficient.

For the installation of this accessory see the figure below and the instructions supplied with the external probe.

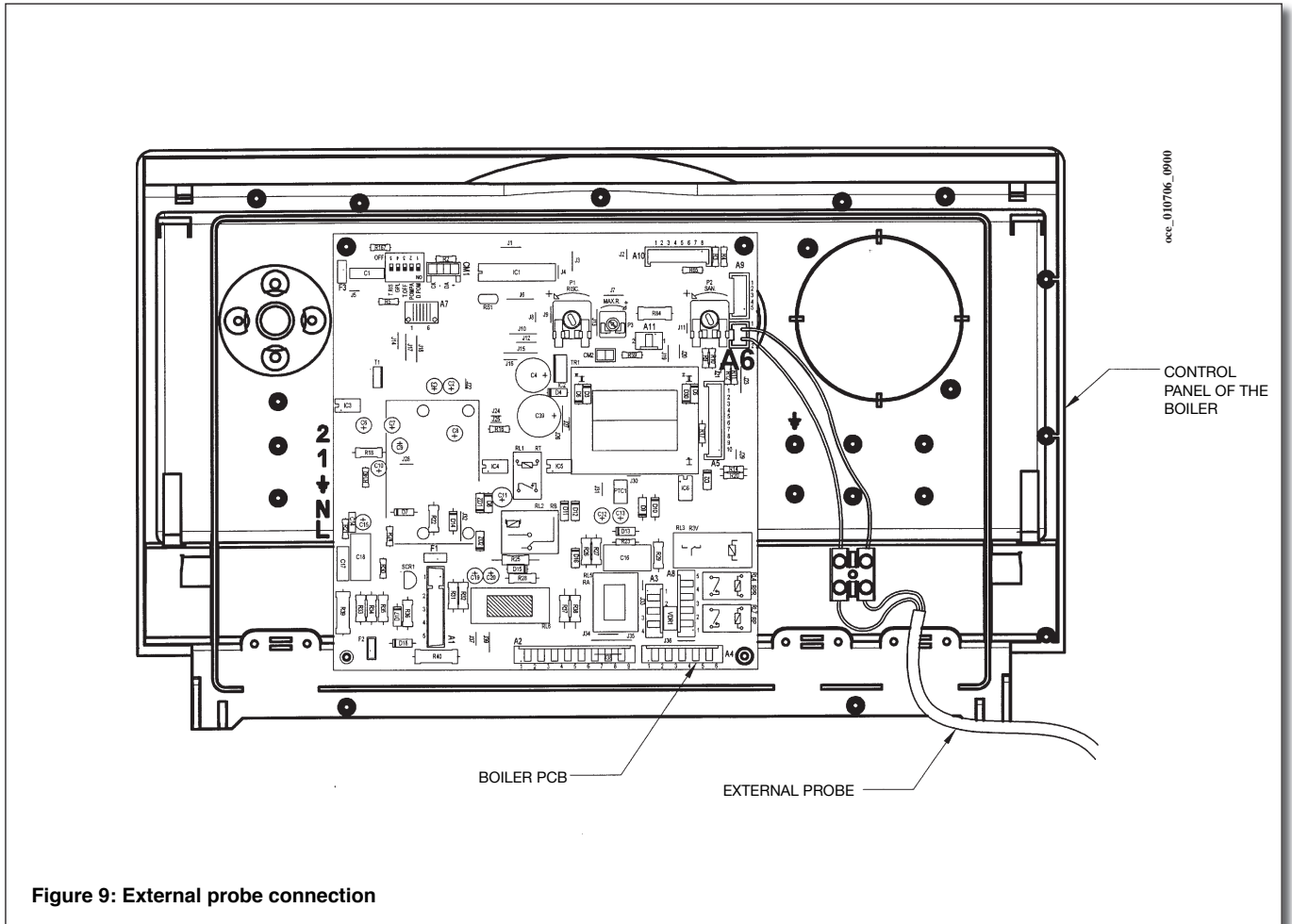

### 10.1. Installation and connection of the external probe

The external probe has to be installed on an external wall of the building observing the following advices:

- Install it on a wall which is situated in the north-north/east direction, avoiding the direct radiation of the sun rays.
- Avoid damp and mouldy walls.
- Verify the wall is sufficiently thermal isolated.
- Avoid its installation near electric fans, flue pipes or chimneys.

Fix the external probe to the wall with the two plugs supplied with the

probe, following the technical instructions supplied with the probe. Electrical connection of the external probe has to be done using two wires having a minimum section of 0.5 mm<sup>2</sup> and a maximum length of 20 m (it is not necessary to respect the polarity).

The connecting cable boiler-probe has to be fixed on one side to the terminal board of the probe (blocking it with its sealed cable clamp) and on the other side to the terminal board present on the boiler.

The cable has to come out from the boiler through one of the cable clamp present on the boiler.



## 10.2. Range of operating curves

When the external probe is connected, the temperature regulation device (knob) of the heating circuit regulates the Kt coefficient. The pictures here below show the correspondence between the knob position and the set curves. It is possible to set also curves between the ones shown in the picture.

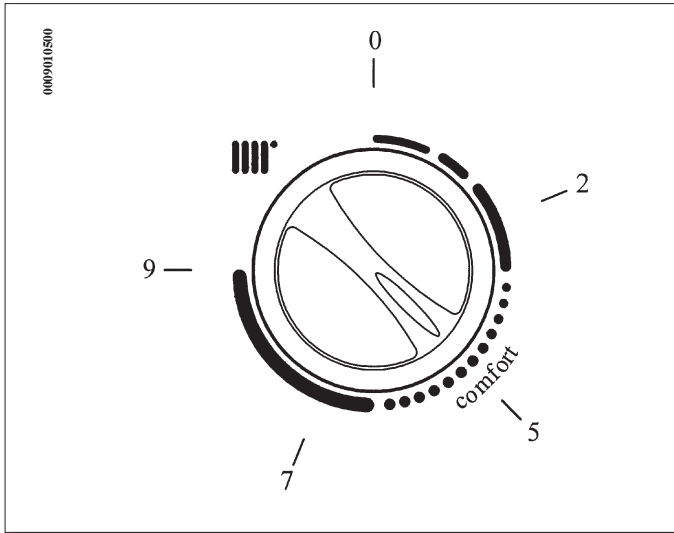

**IMPORTANT:** the range of heating flow temperature  $T_M$  depends on the position of the jumper or switch T.RISC. ( see paragraph 13). The maximum possible temperature setting is 85 or 45 °C.

## 11. Connection of the climatic regulator QAA73 (accessory on demand)

Connection of the climatic regulator QAA73 to the boiler PCB must be made through an interface card, supplied as accessory. This interface card must be connected to A7 connector of the boiler PCB. QAA73 has to be connected to terminals (+) and (-) of the terminal board supplied with the regulator. It is not necessary to respect the polarity (see figure 10)

**When you install the QAA73, you must remove the room thermostat jumper present on the power supply terminal board (terminals 1 and 2).**

See the instructions enclosed with the accessories for their correct installation and use.

Instructions given with the QAA73 also include the following information:

- Parameters settable by the user;
- Choice of the language;
- Use of Information key.

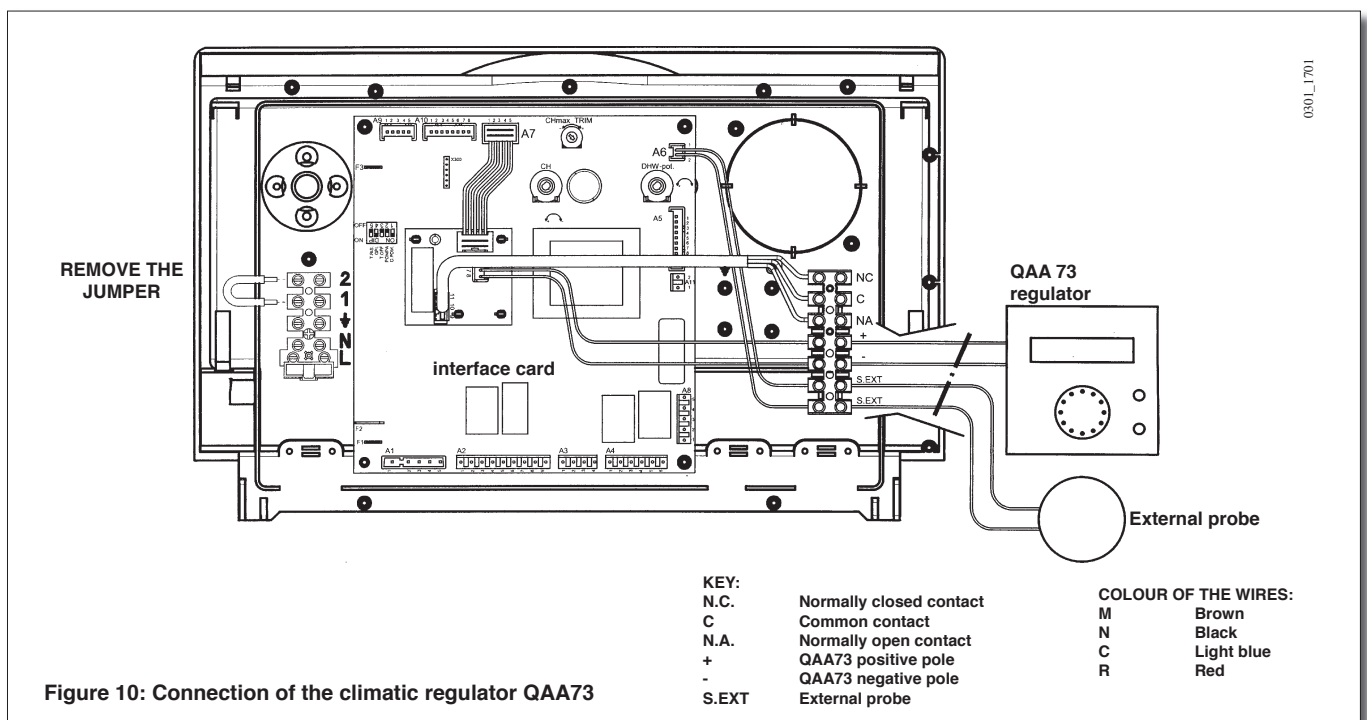

Figure 10: Connection of the climatic regulator QAA73

### QAA73: parameters settable by the installer (service)

When the two PROG keys are pressed simultaneously for at least three seconds, it is possible to enter the list of parameters to display or to modify by the installer.

Press one of the PROG keys to change the parameter to display or to modify.

Press [+] or [-] to modify the value displayed.

Press one of the PROG keys again to save changes.

Press the information key (i) to exit programming.

The following section lists only the most commonly used parameters:

Line	Parameter	Range	Factory setting
70	HC1 Heating curve slope	2,5...40	15
72	HC1 Max. flow temperature	25...85	85
74	Type of building construction	Heavy, light	light
75	Room influence	on HC1 on HC2 on HC1+HC2 none	on HC1
77	Adaptation of heating curve	Inactive –active	active
78	Optimum start control maximum forward shift	0...360 min	0
79	Optimum stop control maximum forward shift	0...360 min	0
90	Reduced set-point of DHW temperature	5...60	35
91	DHW program	24 h/day HC-1h PROG PROG HC PROG ACS	24 h/day
93	ECO function	without ECO with ECO	without ECO

Brief description of the above parameters:

Line	Parameter
70	Selection of heating curve slope
72	Maximum temperature of central heating flow
74	Building insulation type settings
75	Activation/deactivation of the room temperature influence. If deactivated the external sensor must be fitted
77	Automatic adaptation of the heating curve according to the room temperature
78	Max. advance, referred to the hourly program, of the boiler switching on for the room temperature optimization
79	Max. advance, referred to the hourly program, of the boiler switching off for the room temperature optimization
90	ECO function – DHW temperature when the boiler is in OFF mode as programmed in parameter 91.
91	Selection of the type of hourly program for DHW operation. Selection of DHW PROG involves the setting of parameters 30÷36
93	Activation of ECO function. Set also parameter 90

When the external probe is connected to the appliance, the selectable curves are illustrated in graph here below.

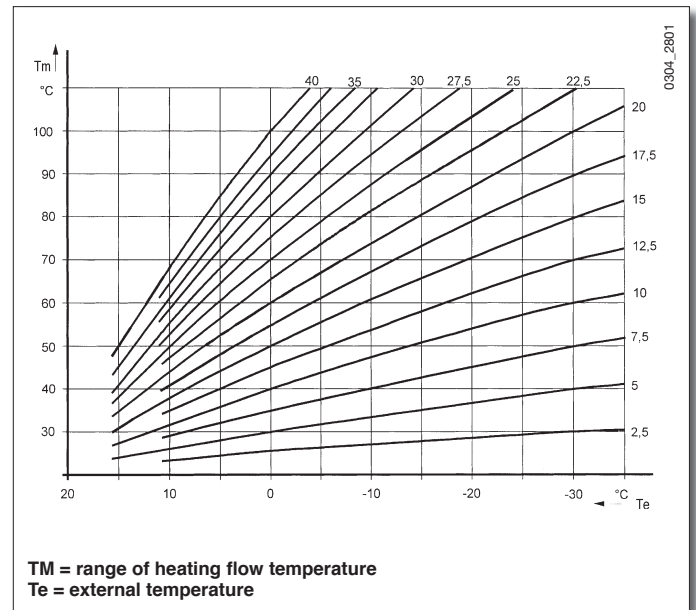

### - fault indication

In case of faults, the QAA73 shows the flashing symbol .

Press information key (i) to display the code and the description of the fault detected.

Code	Display	Fault description
10	External probe	External sensor faulty or parameter 75 deactivated
20	Boiler probe	Heating flow NTC probe faulty
50	DHW probe	DHW NTC probe faulty
60	Room sensor	QAA73 faulty
110	Boiler STB	Safety thermostat operation
133	No flame	Gas supply failure
151	BMU	Boiler PCB error. Switch-off the power supply of the boiler for 10 seconds
160	Fan speed	Fan speed threshold not reached
162	Air pressure switch	Air pressure switch does not commute
164	Heating pressure switch	Hydraulic pressure switch does not commute

## 12. Air vent and release of the pump

### 12.1. Air vent (only for Fi models)

The first time you fill the Central Heating system it is necessary to let the air going out from the pipes and boiler. To achieve this operation it is necessary to proceed as follows:

- Shut off the gas
- Open the front door of the boiler.
- With the system circulation pump running, loosen the plug screwed onto the pump shaft so as to let the air out.
- Screw the pump plug back on.

If necessary, repeat the above described procedure many times. We recommend to collect the water coming out during the above mentioned operations.

### 12.2. Release of the pump

The PCB of the boiler includes a pump anti-blocking function: in case there is no heating demand for 24 hours consecutively, the pump automatically activates for a minute. The anti-blocking function is operating only if the boiler is electrically supplied and the selector (1) is not in position (0).

Anyhow, after a non- working period or at the first lighting of the boiler, a manual release of the pump could be necessary, it is enough to take off the tap screwed on the pump axis, put in a screwdriver and let the rotor turn to release it and help its functioning.

## 13. Regulation on the electronic card (PCB)

With the switches in OFF position:

- T.RISC. Central Heating water temperature range 30÷85°C  
 GPL Operation with Natural Gas  
 T-off 3-minute of stand-by time in Heating mode  
 POMPA 3 minutes of pump post-circulation after room thermostat switch-off.

D.POMPA **This switch must always be in ON position**

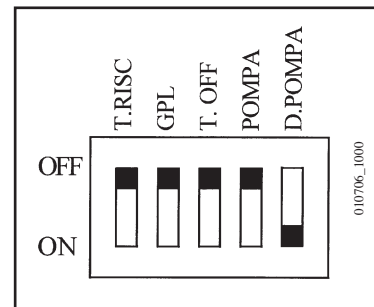

With the switches in ON position:

- T.RISC. Central Heating water temperature range 30÷45°C  
 GPL Operation with L.P.G.  
 T-off 10-seconds of stand-by time in Heating mode  
 POMPA Continuous operation of the pump during heating function

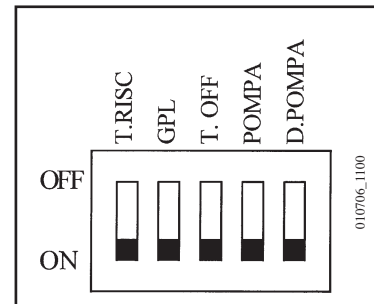

**NB. Make sure that these regulations are done when the boiler is not electrically supplied.**

# 14. Gas conversion

A qualified Service Engineer may adapt this boiler to operate with natural gas (G20) or with liquid gas (G30, G31).

To operate the boilers with a gas different from the one for which the boiler is set, it is necessary to make the following operations:

- Open and remove the frontal door of the boiler.
- Connect two manometers (water manometer, if possible) to the pressure intake (ref. 1 and 2, figure 11) of the gas valve, after loosening the respective screws.

## Replacement of the burner's injectors

- Remove the front box of the sealed chamber.
- Replace the burner's injectors making sure you tighten them, using also the copper washer, to avoid any leakage. Refer to Table III for the injectors' diameter, depending on the type of gas.
- Fit the front box of the sealed chamber back on.

## Modulator voltage change

- Reach the inside of the electrical box as described on paragraph 5.1: "Access to the power supply terminal block".
- Position the respective switch depending on the type of gas (see paragraph 13).

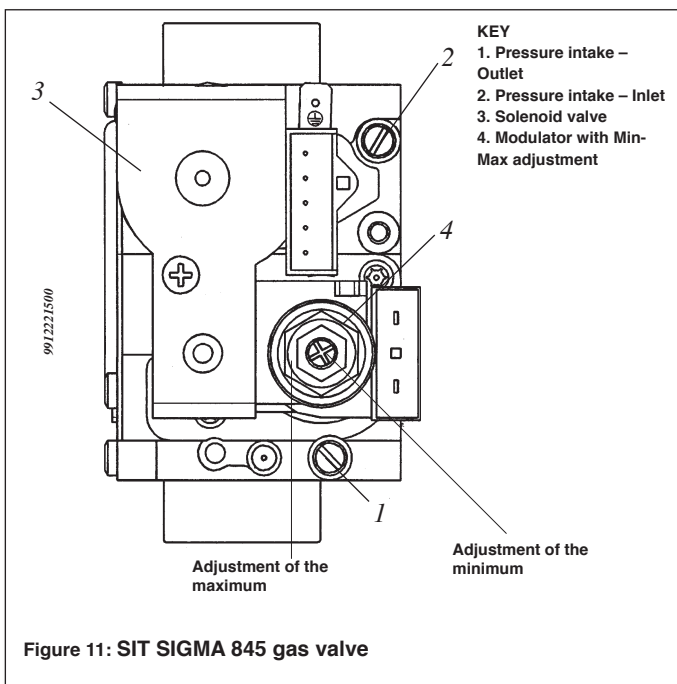

## Adjustment of Maximum and Minimum pressure on the modulator

### NOMINAL OUTPUT (Maximum)

- Open the gas cock and rotate knob (1) to set the boiler to Winter position and wait for the boiler lighting.
- Check that boiler feeding dynamic pressure, as measured at the inlet gas valve pressure intake (ref. 2 figure 11) is correct (30 mbar for butane, 37 mbar for propane, 20 mbar for natural gas).
- Remove the modulator plastic cap, rotate the brass nut until you reach the pressure setting corresponding to the nominal heat output (see table III, according to the model of boiler).

### REDUCED OUTPUT (Minimum)

- Disconnect a modulator cable and unscrew the modulator red screw to reach the pressure setting corresponding to the reduced heat output (see table IV, according to the model of boiler).
- Then connect the cable again, fit the modular plastic cap and seal the fixing screw.

## Adjustment of the Central Heating heat output

It is possible to regulate the Central Heating heat output to the real needs of the system. The following instructions will permit you a correct adjustment:

- Rotate the switch (1) to Winter position, wait for the boiler's lighting (signal of Heating operation (6) switched on).
- Reach the electrical box as described in paragraph 5.1: "Access to the power supply terminal block" and rotate the pressure setting P3 MAX. R of the boiler PCB, to reach the pressure setting at the burner as indicated in tables IV according to the output and the model of boiler.

## Final checks

- Close the control panel.
- Take off the manometers and close the pressure intakes.
- Apply the additional data-plate, specifying the type of gas and setting applied.
- Reassemble the frontal door.

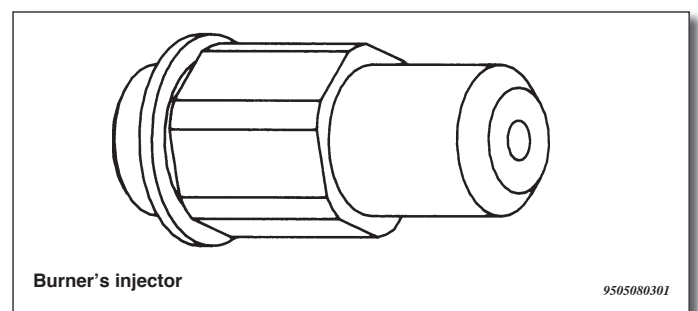

# 15. Table of gas consumption and injectors

**Table III-a** GAS G.20 - p.c.i. = 34,02 MJ/m<sup>3</sup>

Model of boiler	Injectors diameter mm	Power consumption	Maximum pressure	Minimum pressure	Inlet gas pressure mbar
		max/min m <sup>3</sup> /h	(burner) mbar	(burner) mbar	
1.230 Fi - FiN	3,15	2,59/1,43	9,2	2,9	20
1.300 Fi - FiN	3,5	3,49/1,80	10,6	2,9	20

**Table III-b** GAS G.30 - p.c.i. = 45,65 MJ/Kg

Model of boiler	Injectors diameter mm	Power consumption	Maximum pressure	Minimum pressure	Inlet gas pressure mbar
		max/min Kg/h	(burner) mbar	(burner) mbar	
1.230 Fi - FiN	1,75	1,93/1,06	27,7	8,8	30
1.300 Fi - FiN	2,05	2,60/1,34	27,3	6,9	30

**Table III-c** GAS G.31 - p.c.i. = 46,34 MJ/Kg

Model of boiler	Injectors diameter mm	Power consumption	Maximum pressure	Minimum pressure	Inlet gas pressure mbar
		max/min Kg/h	(burner) mbar	(burner) mbar	
1.230 Fi - FiN	1,75	1,90/1,05	35,5	8,2	37
1.300 Fi - FiN	2,05	2,56/1,32	35,1	8,2	37

Note: gas consumption refers to 15°C and 1013 mbar.

**Table IV: burner gas pressure/heat output**

**SLIM 1.230 Fi-FIN**

Burner gas pressure			Heat output		
GAS G20 mbar	GAS G30 mbar	GAS G31 mbar	KW	kcal/h	
	8.8	8.2	11.8	10150	<b>Minimum Heat Output</b>
	9.3	11.9	12.8	11000	
	11.0	14.2	14.0	12000	
	13.0	16.6	15.1	13000	
5.0	15.0	19.3	16.3	14000	
5.7	17.3	22.1	17.4	15000	
6.5	19.6	25.2	18.6	16000	
7.4	22.2	28.4	19.8	17000	
8.3	24.9	31.9	20.9	18000	
9.2	27.7	35.5	22.1	19000	<b>Maximum Heat Output</b>

**SLIM 1.300 Fi-FIN**

Burner gas pressure			Heat output		
GAS G20 mbar	GAS G30 mbar	GAS G31 mbar	KW	kcal/h	
	6.9	8.2	14.9	12800	<b>Minimum Heat Output</b>
	7.7	9.8	15.7	13500	
	8.8	11.3	16.9	14500	
	10.1	13.0	18.0	15500	
	11.4	14.7	19.2	16500	
5.0	12.9	16.5	20.3	17500	
5.6	14.4	18.5	21.5	18500	
6.2	16.0	20.5	22.7	19500	
6.9	17.6	22.7	23.8	20500	
7.5	19.4	25.0	25.0	21500	
8.3	21.3	27.3	26.2	22500	
9.0	23.2	29.8	27.3	23500	
9.8	25.2	32.4	28.5	24500	
10.6	27.3	35.1	29.7	25500	<b>Maximum Heat Output</b>

## 16. Regulation and safety devices

These boilers are built to satisfy all the European rules and prescriptions and in particular are provided with:

- Automatic and electronic ignition  
On demand of regulation devices, the PCB produces the spark at the ignition electrodes and, opening the gas valve, causes the lighting of the burner. At the same time the system checks the regularity of the flame by means of the flame sensing electrode. If there is not flame within the safety time, the boiler blocks and the red signal (8) start to blink. Only after removing the problem it is possible to repeat the ignition rotating selector (1) temporarily in position R.
- Regulation device for the Central Heating water temperature  
This device sets the maximum water temperature in the heating circuit. Its range is from a minimum of 30°C to a maximum of 85°C. To increase the temperature rotate knob (2) clockwise and vice-versa to decrease it.
- Electronic flame modulation  
In relation with the position of the temperature regulation knobs (2) and (3), the electronic control of the boiler regulates the gas pressure to the burner depending on the real conditions of thermal exchange.
- Air - flue gas pressure switch  
This device permits igniting the burner only when the flue gas discharge circuit is fully efficient.  
When there is one of these faults:
  - outlet end-piece obstructed
  - fan jammed
  - "venturi" - pressure switch connection broken

The boiler will remain on standby and the warning light (10) will blink.

---

### IT IS FORBIDDEN TO DISENABLE THIS SAFETY DEVICE

---

- Safety thermostat  
Safety thermostat, which sensor is positioned on the boiler's heating flow, stops the boiler operation in case of overheating of the water which is in the heating circuit, due to an anomaly of the regulation device. In these conditions the boiler blocks (red blinking signal 9 and 8) and only after removing the problem it is possible to repeat the ignition rotating selector (1) temporarily in position R.

---

### IT IS FORBIDDEN TO DISENABLE THIS SAFETY DEVICE

---

- Pump post-circulation  
The post-circulation of the pump, electronically obtained, lasts for 3 minutes after the room thermostat switching off (central heating pump) or at the end of the DHW storage tank heating (sanitary pump, Summer operation with water storage tank).
- Anti - frost device (heating circuit)  
The electronic controls of the boiler include a frost protection function in the Central Heating circuit. This function lights the burner when the flow temperature drops below 5°C and continues until the flow temperature reaches 30°C. This function is active only if the boiler is electrically supplied, selector (1) is not in position (0), and there is gas.

- System to prevent pump sticking  
If there is not heating demands for 24 consecutive hours in heating and/or domestic hot water mode, the pumps start to run automatically for 1 minute. This function is enabled when the boiler is electrically powered and selector (1) is not set at position (0).
- Hydraulic safety valve (heating circuit) (i models)  
This device, calibrated to 3 bar, automatically discharge the water when the system pressure exceeds the set value. It is advisable to connect a drainage to the safety valve.

---

### THE USE OF THE SAFETY VALVE TO DRAIN THE HEATING CIRCUIT IS STRICTLY PROHIBITED.

---

- Regulation device for Domestic Hot Water temperature  
This device sets the maximum temperature of the domestic hot water. Its range is from a minimum of 5°C to a maximum of 60 °C. To increase the temperature rotate knob (3) clockwise and vice-versa to decrease it.
- Anti - legionella function (with water storage tank)  
At weekly intervals, the electronic controls of the boiler bring the water of the tank to a minimum temperature of 60°C. This function is activated also one hour after the boiler has been electrically powered or reset, and in any event after reaching output requirements in heating mode. This function is not enabled if domestic hot water knob (3) is set to minimum or the DHW programming timer does not require heat.
- Anti - frost device (with water storage tank)  
If the domestic water temperature control knob is set to minimum, the electronic control unit will ensure that temperatures do not fall below 5°C.

## 17. Check of the combustion parameters

To measure the combustion efficiency and the hygiene of the products of combustion in situ the boiler is equipped with two ports on the concentric union that are intended for this specific purpose.

To access the ports, take the top cover off the boiler.

One port is connected to the flue gas outlet circuit by means of which it is possible to measure the hygiene of the products of combustion and the combustion efficiency.

The other one is connected to the combustion air intake circuit where it is possible to check for any recirculation of the products of combustion in the case of coaxial ducts.

The following parameters can be measured via the port connected to the flue gas circuit:

- Temperature of the combustion products.
- Concentration of oxygen (O<sub>2</sub>) or in alternative of carbonic anhydride (CO<sub>2</sub>).
- Concentration of carbon monoxide (CO).

The temperature of the combustion air must be measured, in the case of coaxial ducts, at the port connected to the air intake circuit. In the case of separate ducts, it must be measured in the zone in front of the burner by inserting the measuring sensor on the silicone pad in the front box of the sealed chamber (spark plug cable gland).

## 18. Specifications of flow rate/head at the plate

(Fi models only)

The pump used is the high-head, low-noise type suited for use in any kind of single or dual pipe heating system.

The pump, fitted in the boiler, is fitted for operation at top speed (III).

The first speed is not to be used since the flow rate/head specification does not meet the conditions of normal use.

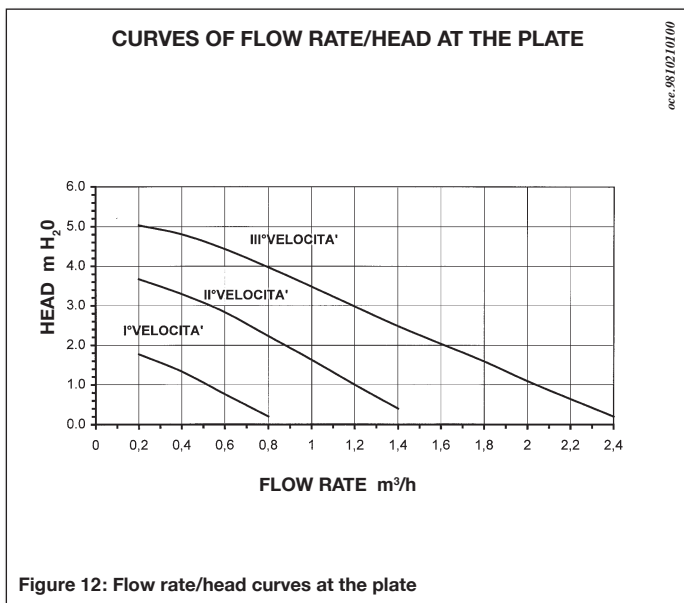

## 19. Hydraulique resistance performances

(FiN models only)

boiler models	1.230 FiN	1.300 FiN
Flow resistance $\Delta t = 15^\circ\text{C}$ mm H <sub>2</sub> O	45	30

$\Delta t$  = difference between heating flow temperature and heating return temperature.

## 20. How to service and clean the boiler

**For a regular and economy operation of the boilers, It is necessary to check, clean up and periodically revise the appliance. We recommend to do these operations around every year.**

Especially it is necessary to check:

- That the installation is full, loaded to the correct water pressure and that the pumps makes to circulate the water in a regular way.
- The lighting and the combustion of the burner.
- The operation of the safety and regulation devices (flue pressostat, safety thermostat, resistance of NTC sensors).
- The efficiency of the electronic flame control (PCB).
- The efficiency of the fan.
- The pressure of the gas to the burner and the gas consumption.
- The cleaning of the flue ducts and the draught of the chimney

It will be necessary to clean also the cast iron exchanger.

### Cleaning of the cast iron exchanger

To clean the cast iron exchanger it is necessary to remove the flue diverter and the burner assembly.

### Dismount of the flue diverter

- Take the top cover off the boiler by pulling it upwards from the rear;
- Take the top cover off the sealed chamber, unscrewing the 8 cross-slotted screws;
- Loosen the screws of the joint securing the fan connection pipe to the concentric union;
- Disconnect the fan's electric leads;
- Disconnect the tubes connecting with the air - flue gas pressure switch;
- Unscrew the two cross-slotted screws of the flue gas conveyer - fan and remove the rear bracket;
- Completely remove the flue gas conveyer by raising it upwards

It is recommended to replace the sealing of the flue diverter at every dismounting.

### Dismount of the burner assembly

- Remove the front box of the sealed chamber.
- Unscrew the three nuts fixing the plate to the cast iron exchanger.
- Disconnect the gas supply pipe acting on the joint positioned after the gas valve
- Remove the ignition and flame sensing electrodes
- After having performed the above operations, the burner group can be drawn out from the cast iron body. It is advisable to replace at every removal the insulating panel in ceramic fibre.

It is possible to effect the cleaning of the cast iron body with a brush in the channels of smoke.

**ATTENTION: After many intervention that concerns the gas circuit it is absolutely necessary to check the perfect tightness of the joints and there are no losses of a gas. We recommend however that these operations are carried out by a Qualified Service Engineer.**



## 21. Technical data

Modello caldaia - <i>Modelo caldera</i>		Fi Models		FiN Models	
		1.230 Fi	1.300 Fi	1.230 FiN	1.300 FiN
Nominal heat input	kW	24,5	33	24,5	33
Reduced heat input	kW	13,5	17	13,5	17
Nominal heat output	kW	22,1	29,7	22,1	29,7
Reduced heat output	kW	11,8	14,9	11,8	14,9
Number of cast iron elements		4	5	4	5
Maximum pressure in the heating circuit	bar	3	3	3	3
Expansion vessel capacity	l	10	10	-	-
Expansion vessel pressure	bar	1	1	-	-
Concentric outlet duct diameter	mm	60	60	60	60
Concentric intake duct diameter	mm	100	100	100	100
Twin outlet duct diameter	mm	80	80	80	80
Twin intake duct diameter	mm	80	80	80	80
Gas type		methane or LPG	methane or LPG	methane or LPG	methane or LPG
G20 natural gas supply pressure	mbar	20	20	20	20
G30 butane supply pressure	mbar	28	28	28	28
G31 propane supply pressure	mbar	37	37	37	37
Power supply voltage	V	230	230	230	230
Power frequency	Hz	50	50	50	50
Nominal Power	W	170	170	70	70
Weight	kg	121	144	111	134
Degree of protection			IPX 4D		

1 mbar = 10,197 mm H<sub>2</sub>O

1000 W = 860 kcal/h

**BAXI S.p.A.** in its commitment to constantly improve its products, reserves the right to modify the specifications contained herein at any time and without previous warning. These instructions are only meant to provide consumers with use information and under no circumstance should they be construed as a contract with a third party.

# BAXI S.p.A.

36061 BASSANO DEL GRAPPA (VI) ITALIA

Via Trozzetti, 20

Tel. 0424 - 517111

Telefax 0424/38089